



PROVEN & TRUSTED SINCE 1952

Gas Fryer
GBF-80G Series

Operation & Service Manual



MODELS:

Single: GBF-80G

2-Bank: GBF-80/80G

3-Bank: GBF-80/80/80G



CAUTION: Read instructions before using this appliance.

GILES Food Service Equipment

ISO 9001-2015 Certified

2750 Gunter Park Drive West • Montgomery, AL 36109 USA
Phone 334.272.1457 • Fax 334.239.4117 • Phone Toll Free 800.554.4537
Website: www.gfse.com • Email: services@gfse.com

66307
REV-C
ECO3332
9/25/2024
PRINTED IN USA

IN A PROMINENT LOCATION near the appliance, post instructions for actions to be taken in the event any person smells gas in the operating area. This information can be obtained by contacting your local gas utility company.

FOR YOUR SAFETY

DO NOT store or use flammable liquids or materials, or materials which may produce flammable vapors, in the vicinity of this, or any appliance.

 WARNING

- Improper installation, adjustment, modification, service, or maintenance can result in property damage or personal injury, even death.
- Read the installation, operating & maintenance instructions thoroughly before installing, operating, or servicing this appliance.



LIMITED WARRANTY

- Subject to the terms and conditions of this Limited Warranty as herein stated, all Giles Enterprises Inc. (hereafter referred to as "Giles") food service equipment and parts purchased new from an authorized Giles representative are warranted as to defects in material or workmanship for a period of twenty-four (24) months from the date of installation, provided, however, that with regard to labor costs in connection with this warranty, see below. All installations must be made by a qualified installing agency in accordance with all applicable codes and/or regulations in the jurisdiction in which installed. Limited warranty coverage is extended only to the original owner and is void if the unit is resold.
- During the Limited Warranty period, Giles will replace or recondition, at its factory, any part or parts of this unit which Giles inspectors judge defective, provided the unit has been properly installed, subjected to normal usage, and operated and maintained in accordance with specified procedures. This Limited Warranty does not cover cosmetic damage, and damage due to acts of God, accident, misuse, alteration, negligence, abuse, or use of unorthodox repair methods. All parts replaced under this Limited Warranty carry only the unexpired term of this Limited Warranty. Limited Warranty service may be furnished only by an authorized Giles service representative.
- If Limited Warranty service is requested, Giles will dispatch factory-authorized service representatives to inspect, repair, recondition, or replace units of its manufacture with such labor being rendered without cost to owner for twenty-four (24) months from the date of installation. Otherwise, service, including labor and transportation charges or other expenses, in connection with the removal or installation of any part or parts supplied under this Limited Warranty, are specified on the original sales contract between the purchaser and the authorized Giles representative.
- **Failure to use Giles OEM replacement parts and Giles OEM filters may void this Warranty.**
- Giles reserves the right to change or improve its equipment and/or parts in any way without obligation to alter such equipment or parts previously manufactured.
- Giles makes no further warranties, express or implied, including implied warranties of merchantability or fitness for a particular purpose, and has no other obligation or liability not specifically stated herein.
- Repair or replacement as provided under this limited warranty is the exclusive remedy. Giles shall not be liable for any incidental or consequential damages for breach of any express or implied warranty on this product, except to the extent prohibited by applicable law. Any implied warranty of merchantability or fitness for a particular purpose on this product is limited in duration to the duration of this limited warranty.
- Used Giles food service equipment or parts, or Giles food service equipment or parts not purchased from an authorized Giles representative, carry no warranties, express or implied.

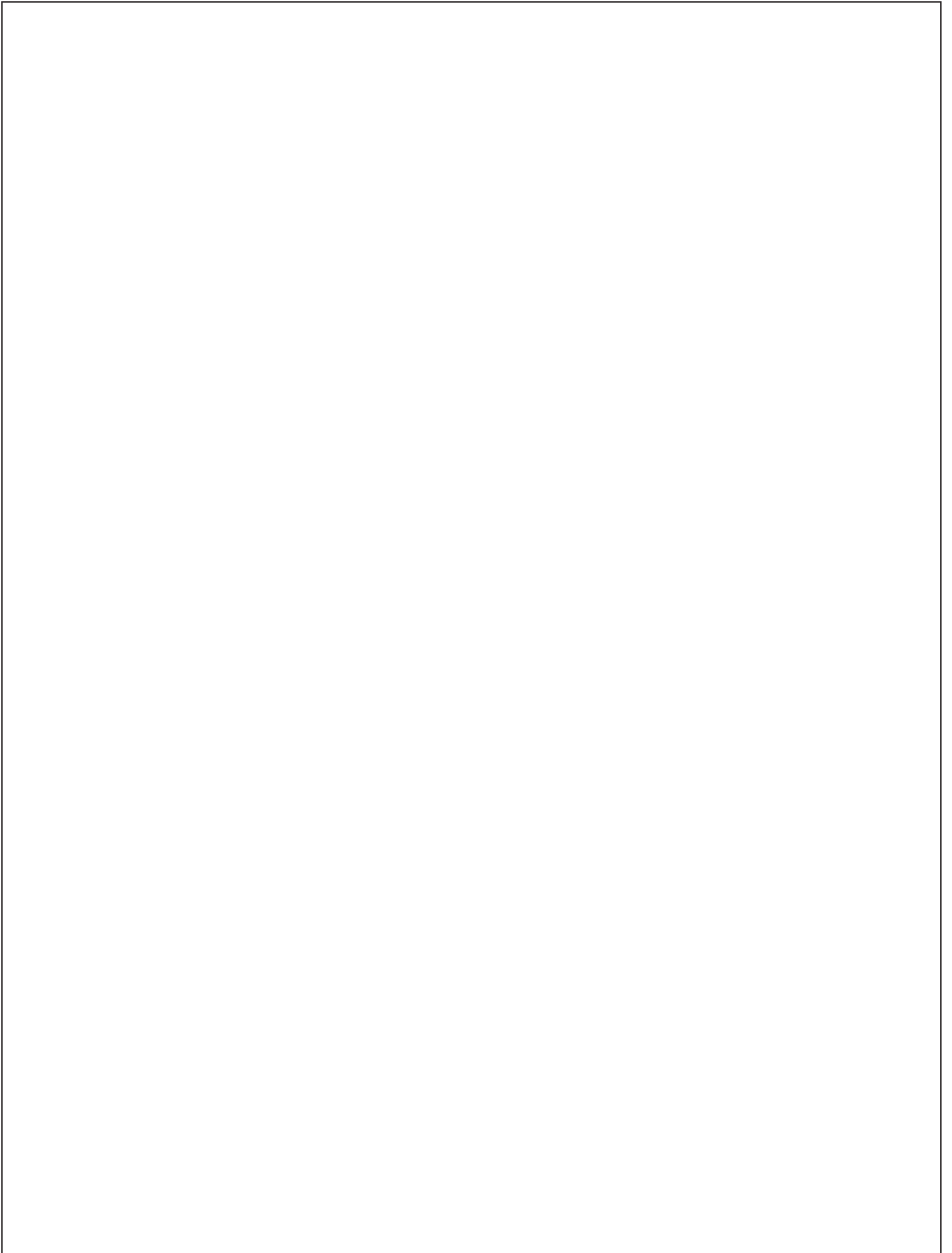

Safety	iv
Safety Overview	iv
Specific Safety Precautions	v
1. Introduction	1
1.1. Construction	1
1.2. Standard Features	1
1.3. Optional Features	1
1.4. Specifications	2
1.4.1. Overall Dimensions	2
1.4.2. Agency Certifications	3
1.4.3. Basket Size	3
1.4.4. Cooking Capacity	3
2. Installation	5
2.1. Appliance Location	5
2.2. Unpacking	6
2.3. Clearances, Gas Supply & Electrical Connections	7
2.4. Ventilation	8
2.5. Utility Requirements	8
2.5.1. Electrical Specifications	8
2.5.2. Fuel Gas Specifications	8
2.6. Electrical Connections	9
2.7. Gas Line Connection	9
2.7.1. Typical Gas Supply Line Connection	9
2.8. Restraint Device	11
2.9. Air Filter Set-Up	11
2.10. Post-Installation Checkout	12
2.10.1. Initial Set-Up for Checkout	12
2.10.2. Power Test	13
2.10.3. Burner System Test	13
2.10.4. Filter Pump Test	14
2.11. Pre-Use Cleaning	14
2.12. Optional <i>KITCHENTRAC</i> ® Remote Equipment Monitoring	15
3. Overview	17
3.1. Control Panel	18
3.2. Lower Cabinet	20
3.3. Filter Pan Assembly	22
3.4. Basket & Elevator Assembly	24
3.5. Accessories Included	26
3.6. Accessories Not Included	28
4. Fryer Operation	31
4.1. Computer Cooking Controller	32
4.1.1. Keys and Functions	32

4.1.2.	Controller General Overview	34
4.1.3.	Setting the Cooking Temperature	35
4.1.4.	Manually Setting the Cook Time	36
4.1.5.	Working with Menu Item Presets	37
4.1.5.1.	Editing a Menu Item Preset	38
4.1.5.2.	Selecting a Menu Item Preset for Cooking	42
4.1.6.	Cooking Cycle - General Overview	43
4.1.7.	Other Controller Features	44
4.1.7.1.	Manually Operating the Basket Lifts (if equipped)	44
4.1.7.2.	COOL Mode	45
4.1.7.3.	AUTO-COOL Feature	45
4.1.7.4.	Boil-Out Mode	45
4.1.8.	Controller User Settings	46
4.1.9.	PASSWORD Protection	47
4.1.10.	Start-up Procedure	47
4.1.11.	Controller Errors & Alarms	48
4.1.11.1.	Resolving Controller Errors and Alarms	49
4.2.	Cooking Procedure	49
4.2.1.	Filling & Preparing Fryer for Cooking	50
4.2.2.	Loading Product for Cooking	53
4.2.3.	Cooking Cycle Process	54
4.3.	Maintaining Oil Level w/Optional Oil Top-Off Systems	56
4.4.	Normal Shutdown	59
4.5.	Emergency Shutdown	59
5.	Oil & Fryer Maintenance	61
5.1.	Maintenance Supplies & Tools	61
5.2.	Filtering Cooking Oil	62
5.3.	Removing & Disposing of Waste Oil	65
5.4.	Boil-Out Procedure (Cleaning the Fry Vat)	69
5.5.	Cleaning the Filter Pan & Refreshing Filter Media	72
5.6.	Air Filter Maintenance	73
6.	Troubleshooting	74
6.1.	Temperature Control System	74
6.2.	Oil Filtration System	77
6.3.	Basket Lift System (Optional)	78
7.	Parts List	79
7.1.	Part Ordering & Service Information	79
7.2.	Front Header & Control Panel	80
7.3.	Front Lower Cabinet - Single Fryer	82
7.4.	Rear Cabinet - Gas Plumbing	84
7.5.	Rear Cabinet - Oil Plumbing	86
7.6.	Rear Cabinet - Header - Optional Basket Lifts	88
7.7.	Cook Vat & Burner Assembly	90
7.8.	Cook Vat - Probe Layout	92

7.9.	Filter Pan Assembly	94
7.10.	Baskets, Panels & Covers	96
7.11.	Optional Parts - Multi Well Units ONLY	98

Safety Overview

Instructions contained in this manual have been prepared to aid in learning proper procedures for safely installing, operating, servicing & maintaining the *GILES GBF-80G Gas Fryer*.

Throughout the manual, safety precautions are identified by a hazard alert symbol & the key words **DANGER**, **WARNING** or **CAUTION**. Safety information precedes the actions to which it applies. Suggested, recommended, or other noteworthy information is identified as a **NOTE**, or will be labeled as **IMPORTANT!**. Additionally, certain words may be used to indicate specific meaning, or to add emphasis as follows:

- Shall:** understood to be mandatory.
- Should:** understood to be advisory.
- May:** understood to be permissive.
- Will:** indicates a future event or condition to occur.

 **Hazard Alert Symbols** are used in conjunction with the key words to alert operating personnel to potential personal injury hazards and/or poor practices. The symbol will immediately precede precautionary measures which pertain to avoiding the hazard or practice. Adhere to all information presented after these symbols to avoid possible injury, or even death. Failure to do so may also void the factory warranty.

DANGER

Indicates an imminently hazardous situation which, if not avoided, will result in serious personal injury, even death.

WARNING

Indicates a potentially hazardous situation which, if not avoided, could result in serious injury, even death.

CAUTION

Indicates a potentially hazardous situation which, if not avoided, may result in minor to moderate injury. This notification is also used as an alert to unsafe practices.

CAUTION

Used without an alert symbol, to indicate a potentially hazardous situation which, if not avoided, may result in equipment and/or property damage and may void the factory warranty.

NOTE or IMPORTANT!

Identifies suggested, recommended, or other important information.

Specific Safety Precautions:

For your safety, please observe the following precautions when operating or servicing the equipment. Adhering to the following important safety precautions will help personnel avoid personal injury and/or prevent damage to the equipment.

DANGER

- Before cleaning or performing maintenance, place **POWER** switch in the **OFF** position. To remove all power, unplug power cord or turn **OFF** power at the electrical panel supplying power. Close valves on the gas supply line & place fryer's *gas valve handle* in **OFF** position.
- **DO NOT** wash down the appliance interior or exterior with water from a spray hose.
- Failure to comply with **DANGER** notices will result in serious injury, even death; or damage to equipment and/or property and may void the factory warranty.

WARNING

- Prior to installation, consult a qualified electrician to ensure that installation will comply with all electrical requirements & building codes.
- **Appliance must be installed & electrically grounded in accordance with local code, or in the absence of local code, in accordance with the *National Electrical Code, NFPA 70*.** Improper grounding may result in electrical shock to operating personnel. Always refer to local electrical code to ensure proper grounding of this or any other electrical equipment.
- Check the rating label on the unit to determine the proper power supply required. Always consult with an electrician, or other qualified service technician, to ensure that electric circuits (*breakers & wiring*) are of sufficient rating & gauge to power the appliance load. A wiring diagram is provided with the unit to aid technicians.
- Improper installation, adjustment, modification, service or maintenance could result in serious injury, even death, equipment and/or property damage and will potentially void the factory warranty.
- **DO NOT** use or store flammable liquids, or materials that produce flammable vapors, in the vicinity of this or any appliance!
- ***DO NOT (or ALLOW OTHERS to) for any reason, stand or step onto the top of the appliance.*** Cooking oil in commercial fryers can be **EXTREMELY HOT (excess of 330°F [166°C])**. Bodily contact will cause an extremely serious injury. Lids used to sometimes cover cooking vats/pots are not designed to, and **WILL NOT**, support the weight of a person. 
- Failure to comply with **WARNING** notices could result in serious injury, even death; damage to equipment and/or property; and will potentially void the factory warranty.

CAUTION

- The appliance must remain in an upright position.
- Exercise care when removing the unit from shipping pallet.
- **DO NOT** operate the appliance unless you fully understand all components & their intended functions (see **Section 3**). After reading & fully understanding information in that section, closely follow the procedures & instructions in this manual in order to avoid equipment damage or malfunction.
- **To avoid personal injury, it is recommended that thermal hand protection (gloves or mitts) be worn while tended the appliance.** Certain parts of the fryer will become very **HOT** during operation ... temperatures inside the cabinet may exceed **150°F (65.5°C)**! Exercise caution when operating & cleaning.
- Placing foods containing excessive moisture (*or ice crystals on frozen items*) into hot oil, or attempting to load larger than recommended batch sizes can cause “surge boiling” & result in an overflow of **HOT** oil. Exercise due care when loading food ... observe how oil reacts before continuing to load product.
- Be sure the appliance is positioned in a stable, safe location with the caster wheel brakes locked. **DO NOT** operate appliance if not secure. Some jurisdictions may require special anchoring for this type of appliance ... check local code.
- Allow the appliance to be adequately cool (*comfortable to touch*) before cleaning or servicing.
- The appliance is not intended for use by persons (including children) with reduced physical, sensory, or mental capabilities, or those with lack of experience & knowledge, unless they have been given adequate instruction and/or supervision concerning its use by a person responsible for their safety. Keep children away from the appliance.
- Cooked food products must be maintained for specific holding times & at minimum temperatures prior to sale for consumption in accordance with governing health department regulations & guidelines.

CAUTION

- Components exposed on the control panel are impact-sensitive. To avoid damage & maintain proper operation, exercise care when working around, or moving carts, and such, near the appliance.
- **DO NOT** install the unit near combustible walls or materials. Failure to maintain safe distance may result in fire.
- When cleaning the appliance:
 - **DO NOT** steam clean.
 - **DO NOT** use products containing chlorine, or other corrosive chemicals.
 - **DO NOT** use abrasive products, steel wool or scouring pads.
 - **DO NOT** use oven cleaners.
- **DO NOT** alter, add attachments, or otherwise modify this equipment!
- Failure to comply with **CAUTION** notices may result in damage to equipment or property, and void the factory warranty.

NOTE:

- Comply with all appropriate state and/or local health regulations regarding food safety & cleaning/sanitization of equipment and accessories.

1. Introduction

Thank you for your purchase of a Giles single model **GBF-80G Gas Fryer**, or a multi-well version **GBF-80/80G** or **GBF-80/80/80G**, manufactured by GILES Food Service Equipment; Montgomery, Alabama (USA), hereafter referred to as "Giles". Every unit is thoroughly inspected & tested prior to shipment in efforts to ensure that it will operate flawlessly when received & installed. With proper care & maintenance the appliance will provide years of trouble-free service.

To help protect your investment in this state-of-the-art cooking equipment, we recommend that you take a few moments to become familiar with all of the procedures presented in this *Owner's Operations Manual*. Adhering to these recommended procedures will help minimize potential for costly downtime & future repair expenses. **Please retain manual for future reference.**

NOTE: Due to continuing improvements & product enhancements, some of the illustrations shown in this manual might not exactly depict current models.

1.1 Construction

Constructed of 18 & 20 Ga. 304 series stainless steel formed sheet metal.

1.2 Standard Features

Computer Controller - Dual timers, controls cooking oil temperature & cook time while storing up to fifty (50) programmable *Menu Item* cooking presets. Continuously monitors fryer operation and displays operating instructions, warnings & alarms - **DRAIN OPEN, LOW OIL LEVEL, MAX. ELEMENT TEMP**, etc. Features **BOIL-OUT** program, **COOL MODE, FORCE FILTER** function, available password security, multiple display language selections & enhanced safeguards against accidental oil fire.

Dual Burner system - A unique, patented heat exchanger design efficiently delivers maximum BTU output while reducing energy consumption.

On-board Oil Filtration System - Completely self-contained system helps to increase the useful life of cooking oil. Features a robust 1/2 HP pump ... designed to perform an oil filtering cycle within approximately five (5) minutes.

Push-To-Start Power - After a power interruption, an operator must press the **[START]** key to power-up the appliance. This feature will comply with code requirements in some jurisdictions.

Multi-Well Versions - Standard multi-well versions of **(2) or (3) banked units** are available. Certain unique oil management options (*not available for single units*) can be added to the models when ordered.

1.3 Optional Features

Automatic Basket Lifts - Operation is by the fryer controller ... automatically lowers & raises cooking baskets of product at beginning & end of cooking cycles ... prevents over-cooking issues due to operator inattention.

KITCHENTRAC® WiFi Connectivity: Provides full-time remote monitoring of fryer cooking activity & operation via your internet connected devices (*laptop, tablet, smartphone*). Keep track of loads cooked, idle-time, oil filtering, menu sales trends & many other analytics associated with cooking equipment utilization. *Basic service is free with purchase of the option ... advanced service levels require a monthly usage fees.*

Sustainable Filter Media [purchased separately] - Stainless steel, woven-wire mesh, sustainable *Filter Screen* used as a direct replacement for paper filter media. Reusable & durable ... with proper care it can last for many months. Helps reduce cost of operation & the waste stream from the kitchen.

Oil Level Top-Off System (Multi-Well Models ONLY) - Top-off vat oil levels with fresh oil supplied from either an on-board storage tank or a *customer-provided* bulk fresh oil supply system. Easy maintenance of vat oil levels ... add oil with a control panel pushbutton switch.

Bulk Oil System Direct Connection (Multi-Well Models ONLY) - Internal factory-installed fryer plumbing provides for direct connection of the fryer to a *customer-provided* bulk oil management system ... fresh oil and/or waste oil disposal ... *can be equipped with either or both.*

1.4 Specifications

1.4.1 Overall Dimensions

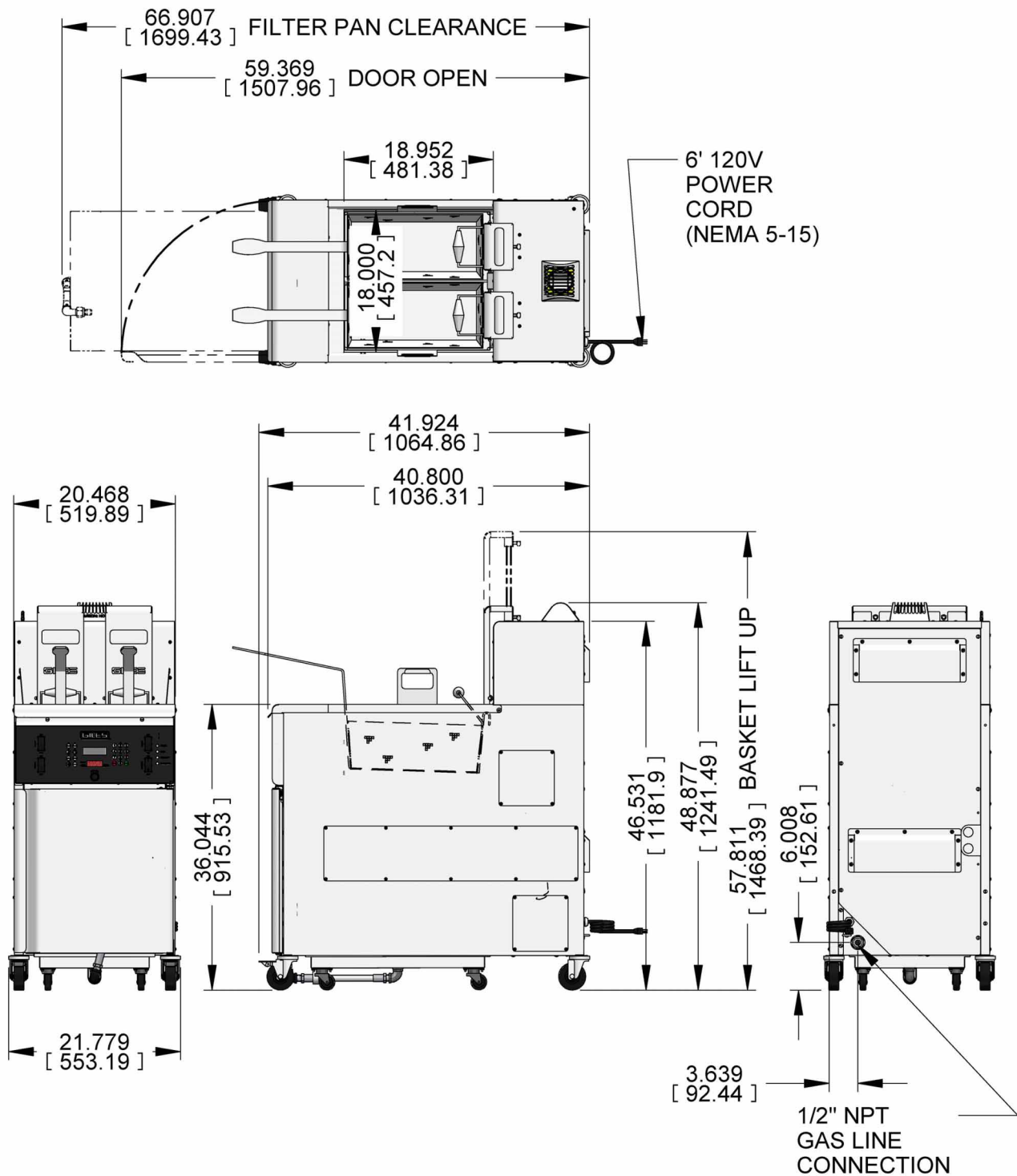

1.4.2 Agency Certifications



1.4.3 Basket Size

Description	Length	Width	Depth	Volume
Standard (2)	17 [431.8]	8-1/16 [204.8]	5-7/8 [149.2]	695 cu in [0.011 c m]

1.4.4 Cooking Capacity

Cooking Oil Capacity		Product Capacity	
Lb [kg]	Gal [l]	Item	Lb [kg]
80 [36.3]	10.4 [39.4]	Cut Chicken <i>[3 to 3-1/4 lb Bird]</i>	18-3/4 [8.5]*
		French Fries <i>[3/8 Crinkle Cut]</i>	5 [2.3] 2-1/2 lbs/bskt

* Without Baskets

CAUTION

Exceeding the product load capacity or over-filling fry vat with oil may result in personal injury and/or damage to equipment or property.

2. Installation

This section summarizes procedures necessary for proper installation of the **GBF-80G** gas fryer. To avoid personal injury or damage to the equipment, please ensure these steps are properly followed by using the **INSTALLATION CHECKLIST** below. For future reference, initial and date at completion of each item.

CAUTION

Various installation tasks described in this manual **MUST** be performed only by a licensed professional electrician or qualified gas technician/plumber.

NOTE: The appliance must be electrically grounded in accordance with local code, or in the absence of local code, with the **National Electrical Code, ANSI/NFPA 70**, or **Canadian Electrical code, CSA C22.2**, as applicable.

INSTALLATION CHECKLIST

Check	Date	Initial	Section	Description
X	8/18/05	CSY	x.x	Review entire Operations Manual; particularly Section 2
			2.1	Select location for appliance
			2.2	Inspect received unit & unpack
			2.3	Confirm proper clearances
			2.4	Verify proper ventilation
			2.5	Install proper circuit breakers (Licensed Electrician Only)
				Verify fuel gas supply (Qualified Gas Technician)
			2.6	Proper electrical connections (Licensed Electrician Only)
			2.7	Gas line connections (Qualified Gas Technician Only)
			2.8	Fuel gas conversion; Nat to LP (If needed, Qualified Gas Technician Only)
			2.9	Restraint device installed
			2.10	Air Filter Set-up for operation

2.1 Appliance Location

CAUTION

DO NOT MODIFY, ADD ATTACHMENTS OR OTHERWISE ALTER THIS EQUIPMENT

1. Installation location must comply with clearances to combustibles stated in **Section 2.3**.
2. Provide adequate space to allow for easy access when operating or servicing the fryer. Adequate ventilation in the operating area is required and must be vented to the outside ... *no recirculating systems*.

2.1 Appliance Location - continued

3. Verify that electrical power available in the selected location is proper voltage & amp rating. Each appliance requires an **isolated, properly grounded, 120V, 15A (min), non-GFCI circuit**.
4. A stable fuel gas supply must also be available at the desired location. A 1/2" gas supply line, fitted with service shutoff valve is required.
5. Be sure selected location is stable & that the appliance will not move unintentionally. There are locking brakes on front casters ... be sure to keep locked when operating appliance. Some jurisdictions may require special additional anchoring for the appliance ... check local codes. See **Section 2.13, Restraining Device**.
6. The appliance shall be installed, operated & maintained in accordance with the **Standard for Ventilation Control, & Fire Protection of Commercial Cooking Operations, NFPA 96**.

The above information helps to ensure proper installation. If there are questions concerning any aspect of the information in this section, contact **Giles Technical Support** at **800.554.4537** or email **services@gfse.com**.

2.2 Unpacking

CAUTION

- Keep the appliance in an upright (vertical) position while unpacking.
- Exercise due care when removing wooden crating & shipping materials from shipping pallet.
- Exercise due care when lifting & moving the unit.
- Failure to comply with **CAUTION** notices may result in minor to moderate injury, damage to equipment or property & void of the factory warranty.

IMPORTANT!

If the palletized load showed any signs of damage when received, immediately inspect the fryer & the associated items. Immediately notify the freight carrier of all damages.

1. The appliance is secured to a wooden pallet with high-tensile plastic strapping and protected by a wooden crate framework. The entire load is wrapped with machine applied stretch film wrap.
2. Carefully cut & remove the stretch film wrap.
3. Carefully remove the crate framework & cut plastic strapping. Secure & remove all accessory items (*baskets, vat screen, brushes, tools, filter pan, filter pan cover, etc.*). Set these items aside in a safe place and properly dispose of shipping materials.
4. Remove unit from the shipping pallet. The appliance is heavy [*approximately 280 lbs (127 kg) uncrated*]. Extreme care should be taken when lifting or moving the unit to prevent personal injury and/or damage to the equipment. Use sufficient manpower or appropriate handling equipment.

Giles shall not be liable for personal injury incurred due to improper or poor work methods. Equipment damages deemed to be the result of improper handling will not be covered by the factory warranty.

2.3 Clearances, Gas Supply & Electrical Connections

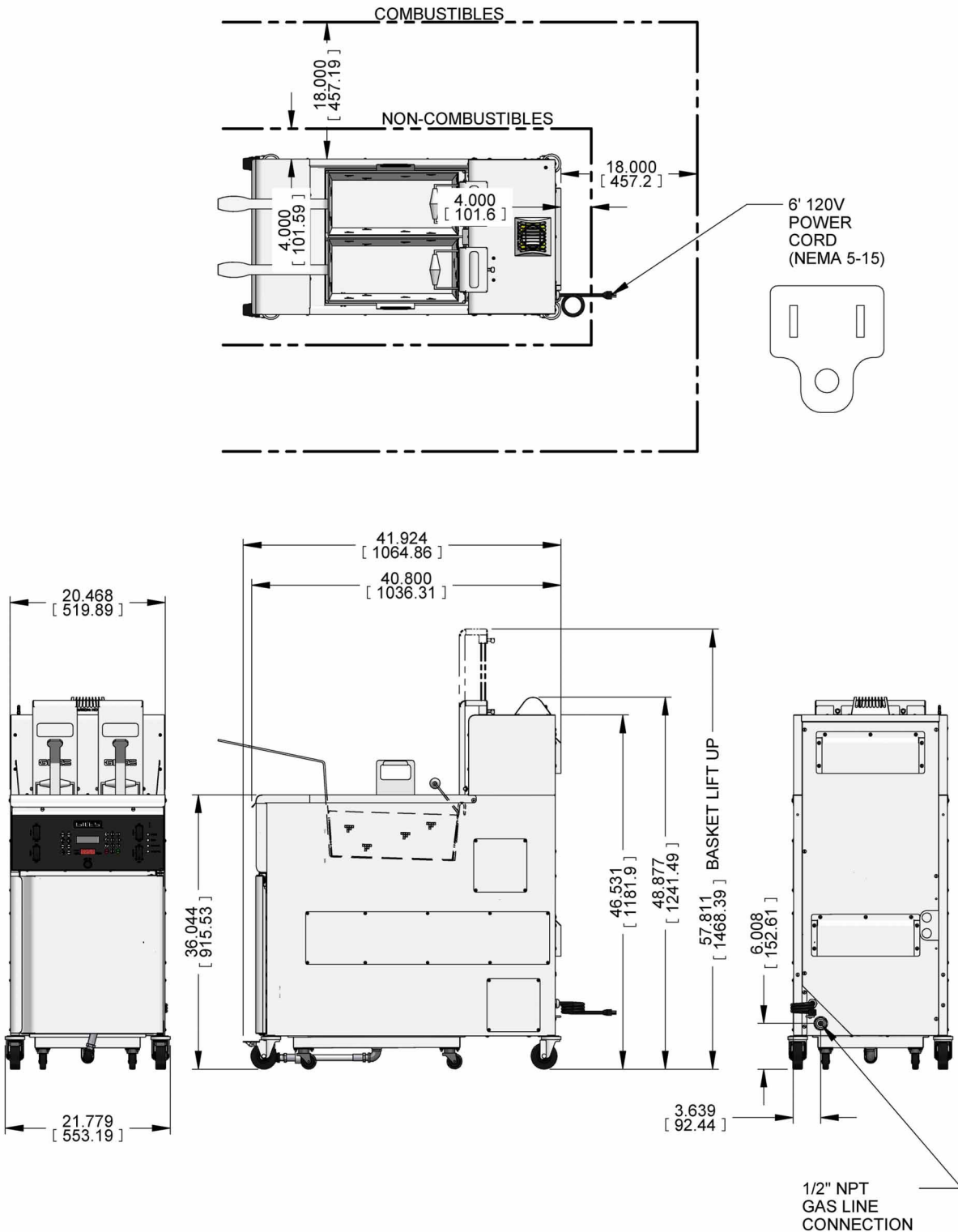

2.4 Ventilation

NOTE:

Guidelines for a ventilation system requirement may differ by locale. Always consult with local authorities to ensure compliance for this appliance.

- **Combustion gases produced by this appliance must be vented to the outside in accordance with the prevailing National Fuel Gas Code, ANSI Z223.1. Vent must terminate with a UL listed *outside vent terminal*. For Canadian installations reference CSA-B149.1 (or .2), Installation Codes for Gas Burning Appliances & Equipment.**
- The appliance is to be installed, operated & maintained in accordance with the Standard for Ventilation Control & Fire Protection of Commercial Cooking Operations, NFPA 96.
- Consult a professional, licensed, HVAC contractor for assistance in designing & specifying a ventilation hood system required for this unit. Recirculating style hoods shall **NOT** be used.

2.5 Utility Requirements

⚠ CAUTION

Fryers must be adequately & properly grounded. Improper grounding may result in electrical shock to operating personnel. Always refer to local electrical code to ensure proper grounding of this or any electrical equipment. Consult with a qualified electrician or service technician to ensure that electrical circuits are of sufficient rating & gauge to power the equipment load.

Table 2.5.1. Electrical Specifications

Model	Voltage	Hz	Ph	Amps	Breaker Required
GBF-80G	120	60	1	5.9	15

Fuel Gas Specification: Giles GBF-80G gas fryers are available from the factory configured to operate with either of the fuel types shown below. **It is important to comply with the indicated gas pressure specifications.**

Table 2.5.2. Fuel Gas Specifications

Fuel Type	Max. Incoming Supply Pressure to Fryer Gas Inlet	Max. Regulated Pressure to Fryer Gas Control Valve	Supply Line Size
Nat. Gas	13.85" w.c. [3.45 kPa]	5" w.c. [1.23 kPa]	1/2"
LP Gas	13.85" w.c. [3.45 kPa]	11" w.c. [2.99 kPa]	1/2"

2.6 Electrical Connections

1. Connect fryer power cord to a **properly grounded, isolated, 120V, 15A (min), NON-GFCI receptacle** ... See **Table 2.5.1**.
2. Fryer has a 6 ft. power cord with a molded **NEMA 5-15P** plug.
3. When igniting burners, the electronic ignition system arcs to ground to generate ignition spark. If the power cord is connected at a **GFCI outlet (ground-fault)**, the circuit interrupter will trip and shutdown fryer power. In order to avoid such nuisance interruptions, it is necessary that only **NON-GFCI** power outlets be used for fryer power.

IMPORTANT!

When installed, appliance must be electrically grounded in accordance with local code, or in the absence of local code, with the **National Electrical Code, ANSI/NFPA 70**, or **Canadian Electrical Code, CSA C22.2**, as applicable.

2.7 Gas Line Connection

⚠ WARNING

- Combustion gases produced by this appliance must be vented to the outside in accordance with the prevailing **National Fuel Gas Code, ANSI Z223.1** ... vent terminating with a UL listed outside vent terminal. For Canadian installations reference **CSA-B149.1 or .2, Installation Codes for Gas Burning Appliances & Equipment**.
- Quick-disconnect devices must comply with the **Standard for Quick-Disconnect Devices for Use with Gas Fuel, ANSI Z21.41 [in Canada CSA 6.9-2014]**.
- Gas connectors & supply lines must comply with **Standard for Movable Gas Appliance, ANSI-69, and Addenda Z21.69 [in Canada CSA 6.10-2015]**.
- Installation may require an additional in-line gas pressure regulator (*customer supplied*) to properly regulate incoming pressure to the fryer's gas inlet connection, see **Section 2.5, Utility Requirements & Table 2.5.2, Fuel Gas Specifications**.
- The unit **MUST** only be installed by a Qualified Gas Equipment Technician.
- Ensure that both the gas service shut-off valve & the fryer gas shut-off valve remain in the [OFF] position until needed.

Verify that the gas service supply line is **1/2" (minimum)** and that a "service" shut-off valve (**customer provided**) is installed. See **Section 2.8.1, Typical Gas Supply Line Connections**.

2.7.1 Typical Gas Supply Line Connection

IMPORTANT!

- Installation must comply with local code, or in the absence of local code, with the **National Fuel Gas Code, ANSI Z223.1/NFPA 54 [in Canada, Natural Gas & Propane Installation Code, CSA B149.1]** including:
 - Appliance must be disconnected from the incoming gas supply line at the **main shut-off valve**, during any testing of piping at test pressures **in excess of 0.50 psi (3.5kPa)**.
 - Appliance must be isolated from the incoming gas supply line by closing the fryer **gas shutoff valve**, during any testing of piping at test pressures **equal to or less than 0.50 psi (3.5kPa)**.

2.7.1 Typical Gas Supply Line Connection - continued

1. Check the incoming gas supply pressure & compare to **Table 2.5.2**. If necessary install an additional pressure regulator on the supply line to regulate gas supply pressure to fryer's gas inlet connection to a maximum of **13.85" w.c. [3.45 kPa]**. **See the IMPORTANT! notification below.**
2. Install an appropriate quick-coupling on the gas line.
3. Connect an approved 1/2" flexible gas line (**customer provided, purchased separately**) between the supply line coupling and the fryer gas inlet connection on rear corner of unit. Connection is **1/2" NPT**.
Note: This flexible gas line should be long enough to allow ample movement of the appliance to provide access to the quick-coupling, when needed.

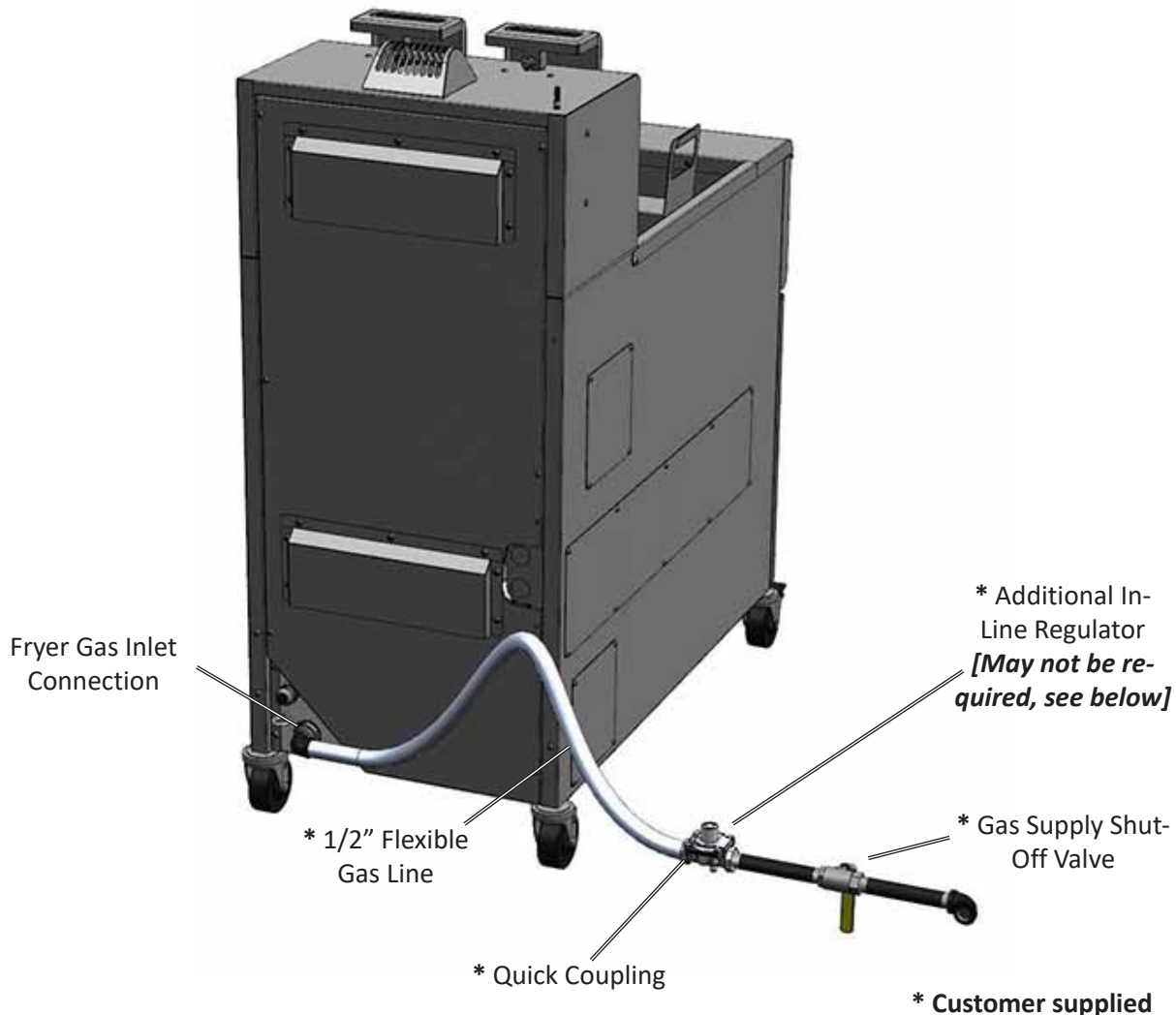

IMPORTANT!

The fryer's on-board gas regulator regulates input pressure to the fryer gas control solenoid valve, as shown in **Table 2.5.2** above. This regulator is rated for a **maximum pressure of 13.85" w.c. [3.45 kPa]**. If supply pressure from the **gas utility company (or LP gas source) exceeds this maximum pressure, an additional in-line pressure regulator must be installed upstream of the fryer to regulate pressure delivered at the fryer gas inlet to a target of 7" w.c. [1.74 kPa] for Nat or 12" w.c. [2.74 kPa] for LP.**

2.8 Restraint Device

The appliance requires use of an appropriate *Restraint Device (customer provided)* to prevent unintentional movements that might place excessive strain on electrical & gas connections. The restraint length must be shorter than both the electrical cord & flexible gas line and the restraint anchor must be attached to an immovable structure. Use a quick-connect latch on one end of the cable so that it can be easily removed when necessary.

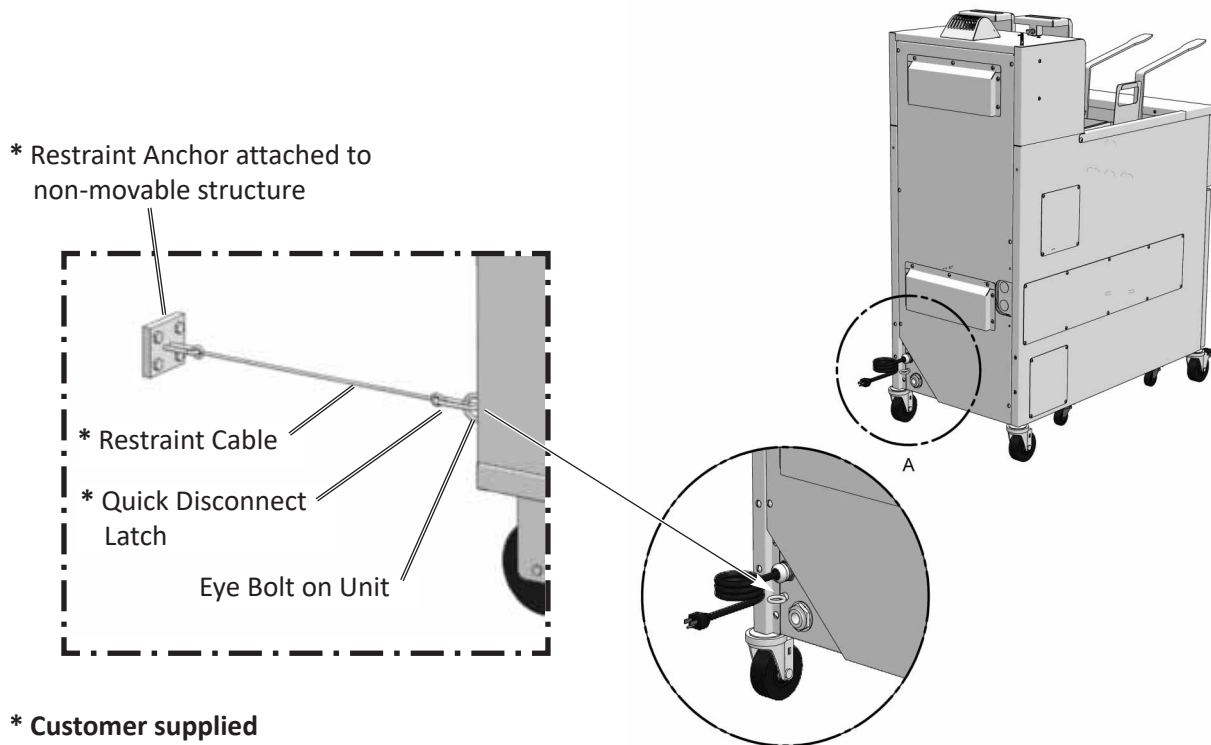

2.9 Air Filter Setup

The *Intake Air Filter* is located inside the fryer cabinet. During shipment, a temporary bracket is attached to secure it in place. This bracket should be removed & discarded prior operation.

1. Open cabinet door.
2. Loosen the two (2) screws holding bracket (no need to remove)
3. Remove bracket & discard.
3. Re-tighten the screws.

This filter must be cleaned routinely to ensure sufficient clean air is being provided to the burners for efficient combustion. Replace the filter should it be damaged.

See Section 5.6, Air Filter Maintenance

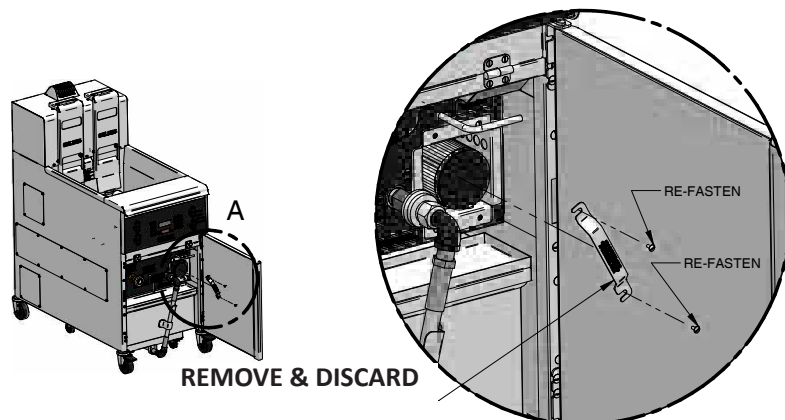

2.10 Post Installation Checkout

Giles prides its quality of workmanship. Every effort has been made to ensure that your new unit is in perfect operating condition when received ... each must pass rigorous quality control inspection & testing prior to shipment. To further ensure that the appliance operates as expected, it is recommended that a brief functional checkout be performed after installation is complete to verify the install procedures.

Before attempting the following tests, please refer to Section 3 ... become familiar with the various controls & their functions, then perform the tests described in the following sections to verify the functionality of primary fryer systems. Perform these tests precisely as described ... failure to do so could lead to equipment damage or future malfunction.

2.10.1 Initial Setup for Checkout

Before proceeding with the tests described, initially set-up the appliance as described below.

1. Place **POWER** ① & **HEAT** ② switches in the **OFF** position.
2. Open cabinet door ... if needed, disconnect & remove the Filter Pan ③ from fryer.
3. Place the **DRAIN** valve handle ④ in the **CLOSE** position (indicated by label).
4. Place the **OIL DIVERTER** valve ⑤ in the **[OIL TO VAT]** position.
5. Remove *Vat Screen, Cook Baskets & Basket Carriers (if equipped)* & set aside.
6. Before proceeding, take time to remove any remaining adhesive poly-film from sheet metal surfaces. The film is left on the unit to help safeguard against surface damage during shipping. If not removed now, over time it will become increasingly difficult to remove.

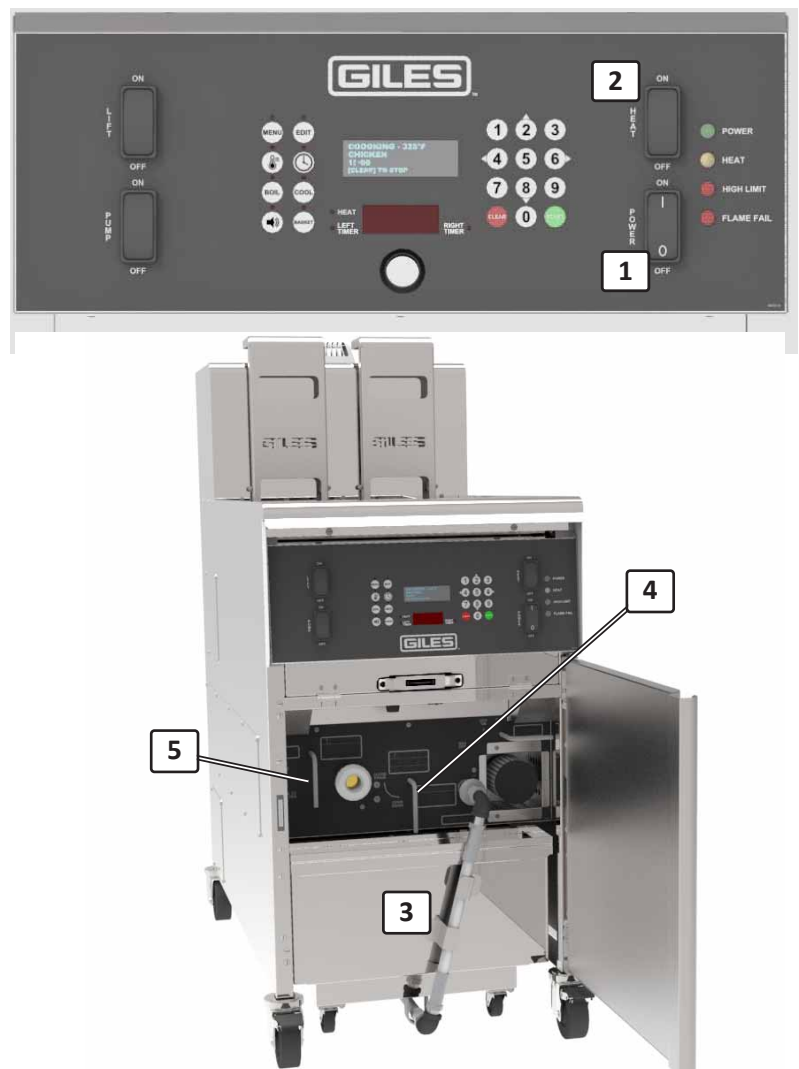

2.10.2 Power Test

The following verifies that the appliance is properly receiving power.

1. Be sure the circuit breaker in the electrical panel that powers the fryer is turned **ON**.
2. Place **POWER** switch ① in **[ON]** position. Green **POWER** light ② should turn **ON** & the controller ③ runs a power-up sequence. When an alarm sounds, press the **[ALARM]** key ④ to silence. You should notice a small red **HEAT** light beside the *lower display*.

If this sequence occurs as described, continue to [Section 2.10.3](#).

If it does not, refer to [Section 7, Troubleshooting](#).



2.10.3 Burner System Test

The following test verifies that the gas burners receive fuel, ignite & heat the Heat Exchanger.

⚠ WARNING

DO NOT touch the Heat Exchanger during this test. It can become very hot quickly & contact may result in severe burn injury.

⚠ CAUTION

This test requires that the burners ignite & burn momentarily without oil in vat. **DO NOT** allow fryer to remain ON for more than 10 seconds. Failure to observe this precaution can damage the Heat Exchanger.

1. Be sure that main gas supply line valve is **OPEN** and Fryer Gas Valve handle inside cabinet is in the **[GAS ON]** position, indicated on label.
2. *Heat exchanger* in vat should be at room temperature. Wipe the tubes with a wet sponge ... enough so that moisture remains on surfaces.
3. Place control panel **HEAT** switch ⑤ in the **[ON]** position. Ignition sequence will begin ... you should hear the ignitor sparking & gas mixer/blower running, followed by combustion noise as burners ignite.

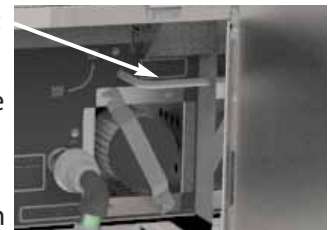

NOTE: If burners do not ignite within an allowed time the fryer will enter **FLAME FAIL** error. If this occurs, return **HEAT** switch to **[OFF]** ... wait 10 seconds & try again.

4. After ignition, the moisture on the surface of *heat exchanger* should dry quickly & noticeable heat should be felt, indicating acceptable heating.
5. If burners do not ignite after two (2) attempts, or appear to only be heating slowly, refer to [Section 7, Troubleshooting](#).
6. If the burners appear to be operational, return **HEAT** switch to **OFF** & proceed with the next test in [Section 2.10.4](#).

2.10 Filter Pump Test

The following test will verify that the Filter Pump is operating correctly.

1. Place the **POWER** switch ① in the [ON] position & open cabinet door.
2. With the filter pan disconnected, place the palm of the hand tightly over the opening of the filter pan quick-coupling ②.
3. Place the **PUMP** switch ③ in the [ON] position & allow pump to briefly run, then return to OFF. If good suction is felt when pump was running, it is operating correctly ... continue to [Section 2.11](#).

If the pump does not run, or no or little suction is felt, refer to the [Section 7, Troubleshooting](#).

If the pump is blowing air out, a service technician will be needed to inspect & correct operation.

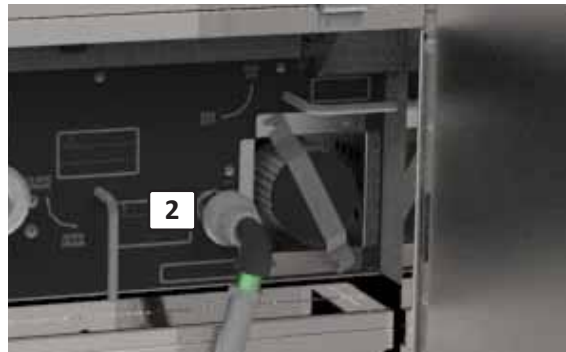

2.10.1 Pre-Use Cleaning

- Before cooking in fryer, perform a [Boil-Out procedure](#) to remove dirt that may have accumulated during shipping and possible residue which may remain from manufacturing processes. See [Section 5.1, Boil-Out Procedure](#). After completion proceed to [Section 2.12](#).
- Thoroughly clean the filter pan to remove dirt or debris that may have accumulated during shipping and possible residue which may remain from manufacturing processes. See [Section 5.2, Cleaning Filter Pan & Replacing Filter Media After Boil Out](#).
- Wash all accessory items (*baskets, basket lift carriers, vat screen, tools, brushes, etc.*) in hot soapy water, rinse & dry thoroughly.

2.12 Optional KitchenTrac® Remote Equipment Monitoring



If you purchased **Giles' Optional KITCHENTRAC®** remote monitoring capability for this equipment, before it is active, you must first set it up, pair the controller with your establishment's WiFi network and connect to the **KITCHENTRAC®** server. **Standard service is included free with purchase of the option and advanced service levels are available for a monthly subscription fee.** To subscribe to the premium services, visit www.kitchentrac.com and click the

SUBSCRIBE NOW tab.

A WiFi router providing a continuous open connection to the internet & located within communication range of the monitored appliance is required for the monitoring service to perform properly.

A detailed **WiFi Connection Manual (Form #66313)** should have been packed with your unit. Follow the steps outlined there to begin realizing the benefits the option provides.

You will be able to stay connected to your kitchen to monitor appliance performance, productivity, menu sales trends, operational status, and much more. You can access the many available analytics by simply logging-in to the **KITCHENTRAC®** website from any computer or internet connected device (*smart-phone, laptop, or tablet*).

Fryer preparation is now complete ... continue to Section 4, Fryer Operation.

3. Overview

The following section provides a brief overview of components, features & accessories associated with the *Giles GBF Gas Fryers*. Please review this section completely before attempting to use the appliance.

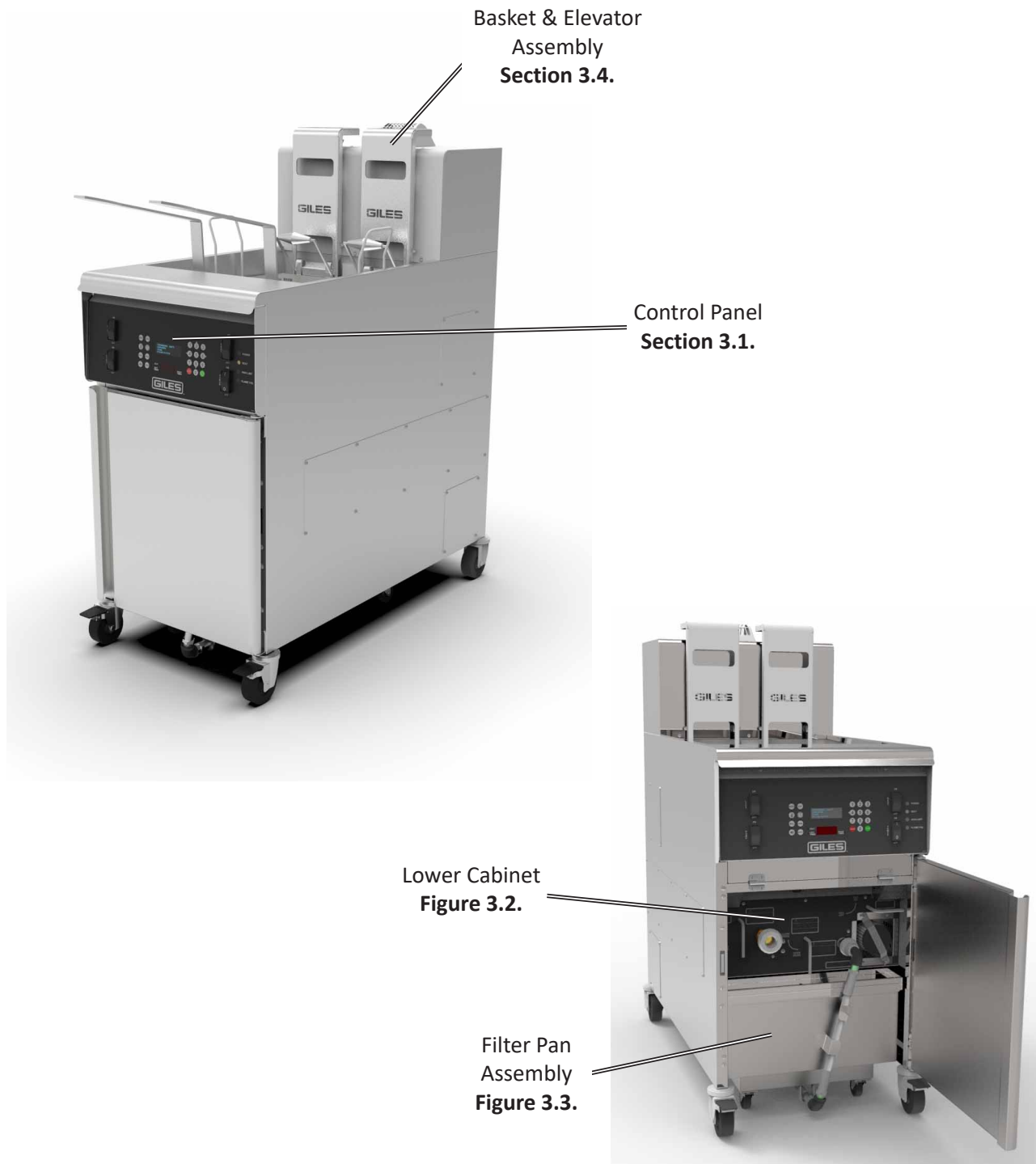

3.1 Control Panel



* Optional feature

3.1 Control Panel

Item	Description	Function
1	POWER Switch	2-position rocker switch, turns appliance power ON & OFF . Pressing top of switch powers ON , pressing bottom powers OFF .
2	HEAT Switch	Placing switch in the [ON] position enables fryer heating. If actual oil temperature is lower than the controller setpoint, the fryer's gas valve opens, gas mixer blower starts & the ignitor sequence begins to ignite burners. When OFF , fryer WILL NOT heat.
3	Computer Controller	Computer controller regulates cooking oil temperature & independently controls cooking time for each basket. Fifty (50) programmable <i>menu item presets</i> are available for creating fryer pre-set for various items. Continuously monitors operation, displays error/alarm conditions & operating instructions. Features key-pad for inputting values & starting activities. Provided function keys will begin specific actions.
4	POWER Light	Green light illuminates when the appliance POWER switch is ON .
5	HEAT Light	Amber light illuminates whenever burners are ON & heating oil. The light cycles ON & OFF during cooking, as controller regulates oil temperature to the setpoint.
6	HI-LIMIT Light	The red HIGH LIMIT light illuminates to signal an overheat condition & indicates that the <i>safety thermostat</i> has tripped to disable fryer heat. Should this light turn ON & alarm sound during operation, refer to the <u>Section 7, Troubleshooting</u> . <u>DO NOT ATTEMPT TO COOK WHEN THE HIGH-LIMIT LIGHT IS HAS TURNED ON!</u>
7	FLAME FAIL Light	The red FLAME FAIL light illuminates when the heating system detects that there is NO flame at the burner ... gas valve automatically closes to shutoff gas flow.
8*	LIFT Switch <i>Optional</i>	Switch is present ONLY when optional <u>Basket Lifts</u> are installed ... Enables & disables the automatic basket lifts ... Lifts are active when ON ... Lifts WILL NOT operate when OFF .
9	PUMP Switch	Turns Filter Pump ON & OFF when filtering cooking oil or when removing used waste oil from the fryer.
10*	"ADD OIL" Switch <i>Optional</i>	Switch is present ONLY when the optional <u>Oil Top-Off feature</u> is installed ... ONLY available for multi-well models. Pushbutton switch ... press & hold to operate either an on-board top-off pump, or the oil pump of a " <i>customer-provided</i> " bulk fresh oil system.

* Optional feature

3.2 Lower Cabinet

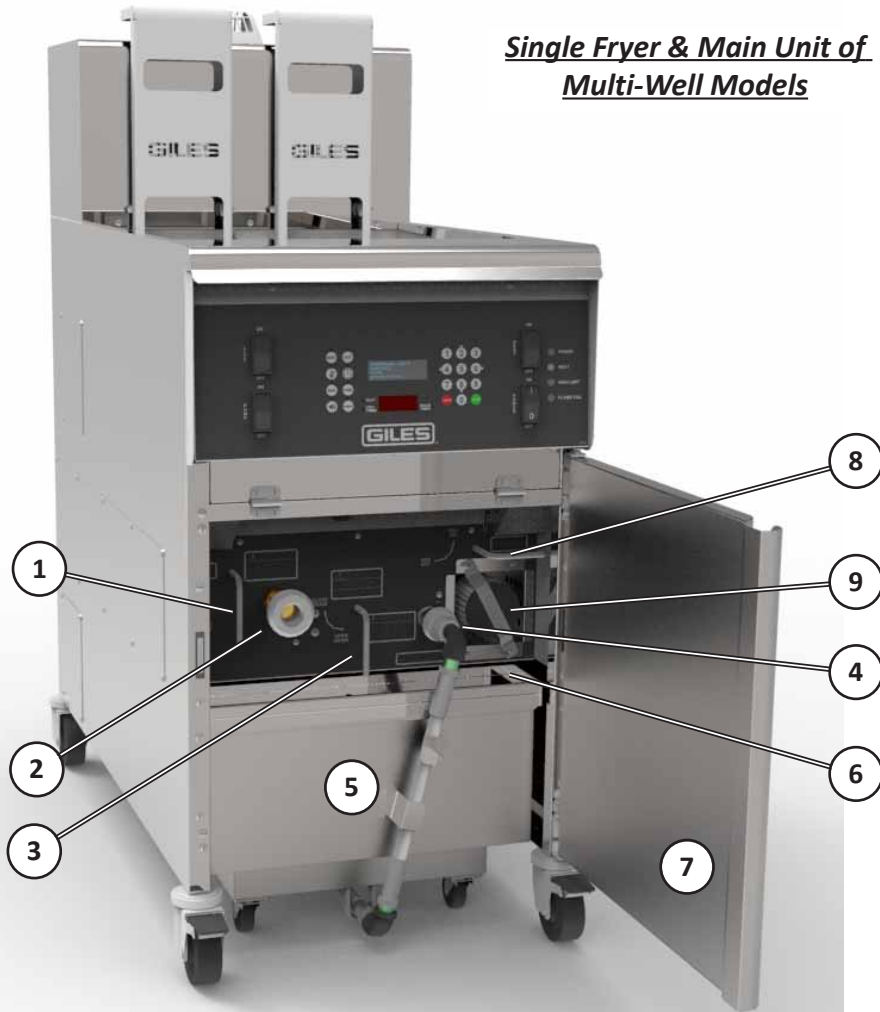

*Right Unit of
Multi-Well Model*

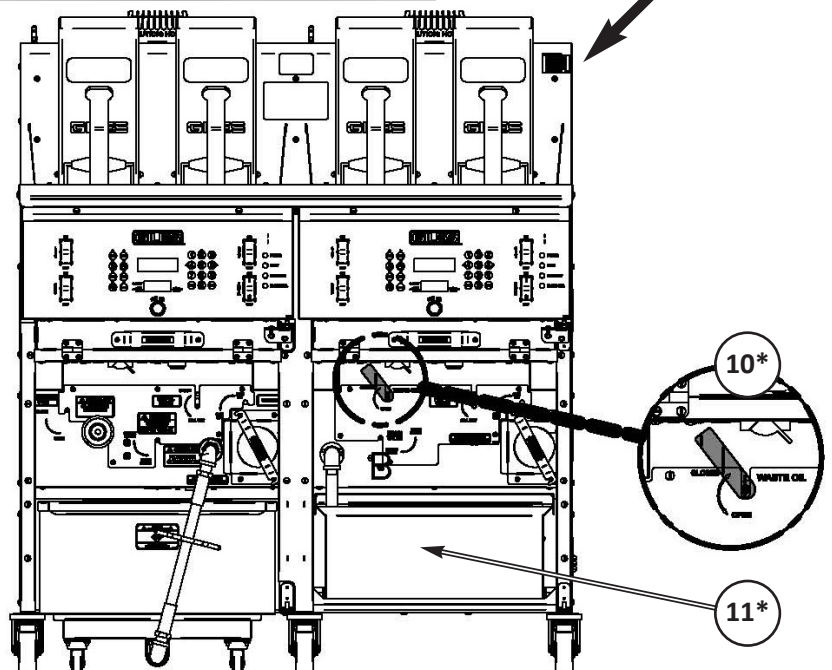

3.2 Lower Cabinet

Item	Description	Function
1	DIVERTER VALVE Handle	Directs the output of the fryer filter pump to, either the fry vat or to the <i>Waste Oil Discharge Hose</i> .
2	<i>Waste Oil Discharge Hose</i> Quick-Coupling	Connects the <i>Waste Oil Discharge Hose</i> to the fryer filter pump system when removing waste oil for disposal.
3	DRAIN VALVE Handle	Actuates the fryer vat drain valve. Always ensure the valve is CLOSED before adding cooking oil or water for boil out. NOTE: Fryer <u>WILL NOT</u> heat unless the drain valve is completely closed & will shutdown if opened, even slightly, while cooking.
4	<i>Filter Pan</i> Quick-Coupling	Connects the filter pan hose to the oil filtration system.
5	Filter Pan	Collects & contains used cooking oil that is drained from the vat & has a filter media that removes cooking residue from used oil to clean & recondition. See Section 3.3 for more detail.
6	Filter Pan Cover	Helps to contain splash & splatter as oil is being drained into the <i>filter pan</i> . When used properly it will help keep floor under fryer & inside of cabinet cleaner. Also, provides protection against oil contamination during filtering operations.
7	Cabinet Door	Access to lower cabinet valve handles & filter pan. The door is field reversible, if desired.
8	GAS SHUTOFF VALVE Handle	Actuates the fryer gas valve ON & OFF .
9	Intake Air Filter	Cleans incoming combustion air drawn in by the pre-mix blower. Requires periodic cleaning & should be replaced approximately every six (6) months.
10*	<i>Bulk Waste Oil Valve</i> Optional	<u>ONLY available for multi-well models ... Valve is present ONLY when the optional Bulk Waste Oil feature is installed ... located in right-hand unit.</u> With the <i>Bulk Waste Oil</i> feature, fryer is connected directly to a “customer-provided” waste oil system. When removing waste oil, placing valve in OPEN position will direct the output of fryer’s filter pump to a bulk waste oil collection tank.
11*	<i>On-board Fresh Oil Tank</i> Optional	<u>ONLY available for multi-well models ... Present ONLY when the optional On-board Oil Top-Off feature is installed ... located in right-hand unit.</u> To top-off oil level with this system, press & hold the control panel “ ADD OIL ” push-button switch to pump fresh oil from this tank & deliver to a selected vat. <i>Oil supply in this tank must be physically maintained by operating personnel using jugs of fresh oil.</i>

3.3 Filter Pan Assembly

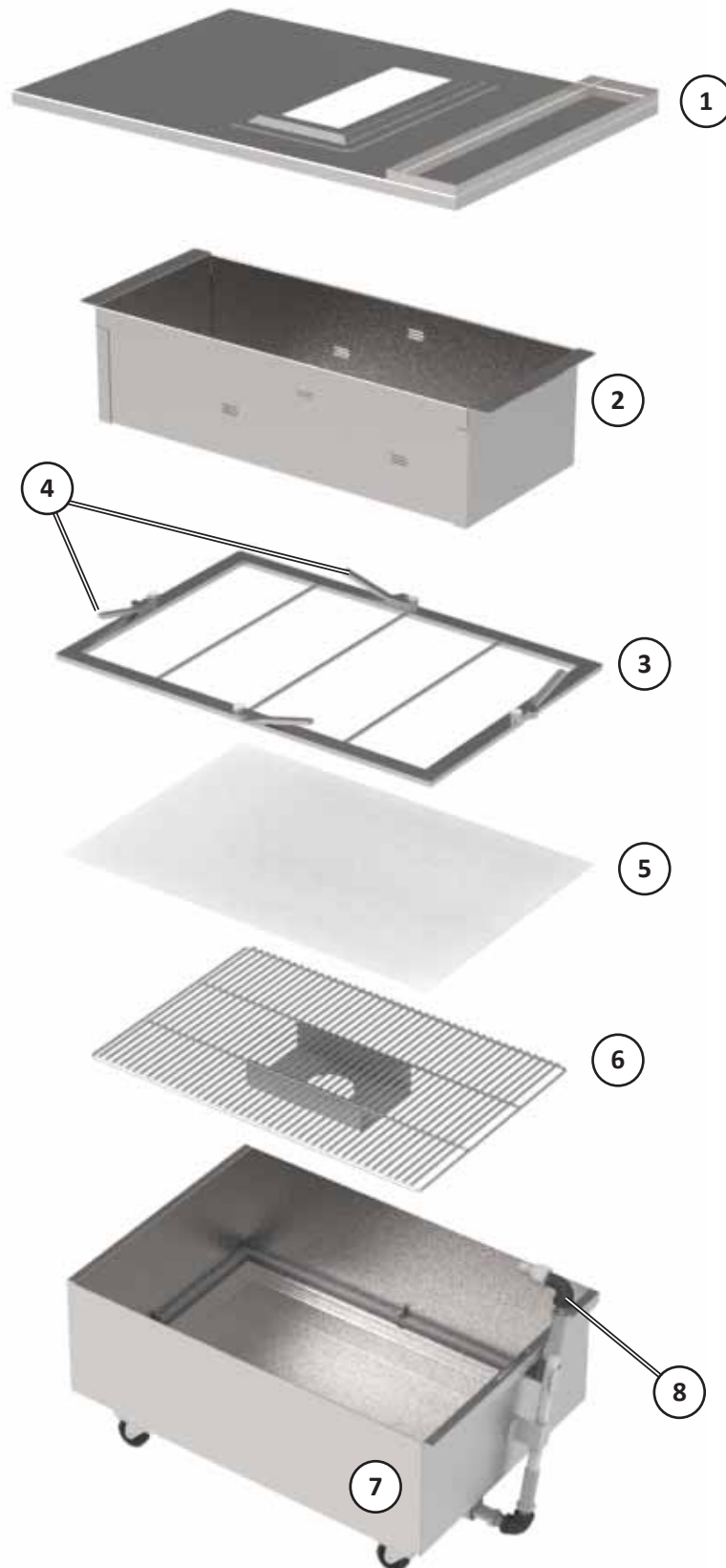

3.3 Filter Pan Assembly

Item	Description	Function
1	Filter Pan Cover	Helps contain oil splash & spatter when oil is being drained into the filter pan to minimize clean-up required for floor & cabinet interior.
2	Crumb Screen	Filter Pan insert designed to capture large breading crumbs & cooking residue as oil drains from vat. Helps minimize crumb build-up in the filter pan.
3	Hold-Down Frame	Secures filter media tightly against filter pan bottom to provide a good suction seal for the filter pump ... improper placement will likely affect pump performance.
4	Hold-Down Levers [4}	Locks Hold-Down Frame in place. Failure to have these Levers properly engaged will potentially cause poor filter pump performance.
5	Filter Paper	Standard, disposable, paper filter media. Filters fine sediment & residue from cooking oil during the filtering cycle. <i>Must be used with a quality filter aid powder compound to properly recondition used oil.</i>
6	Filter Pan Screen	Provides support for the filter media.
7	Filter Pan	Collects & contains used cooking oil for filtering ... contains the filter media. The filter pan features casters & is easily removable for cleaning & refreshing of filter media.
8	Filter Pan Quick-Coupler Hose	Connects filter pan to the fryer oil filtration system. Hose must be disconnected before the pan can be removed from fryer.

3.4 Basket & Optional Elevator Assembly

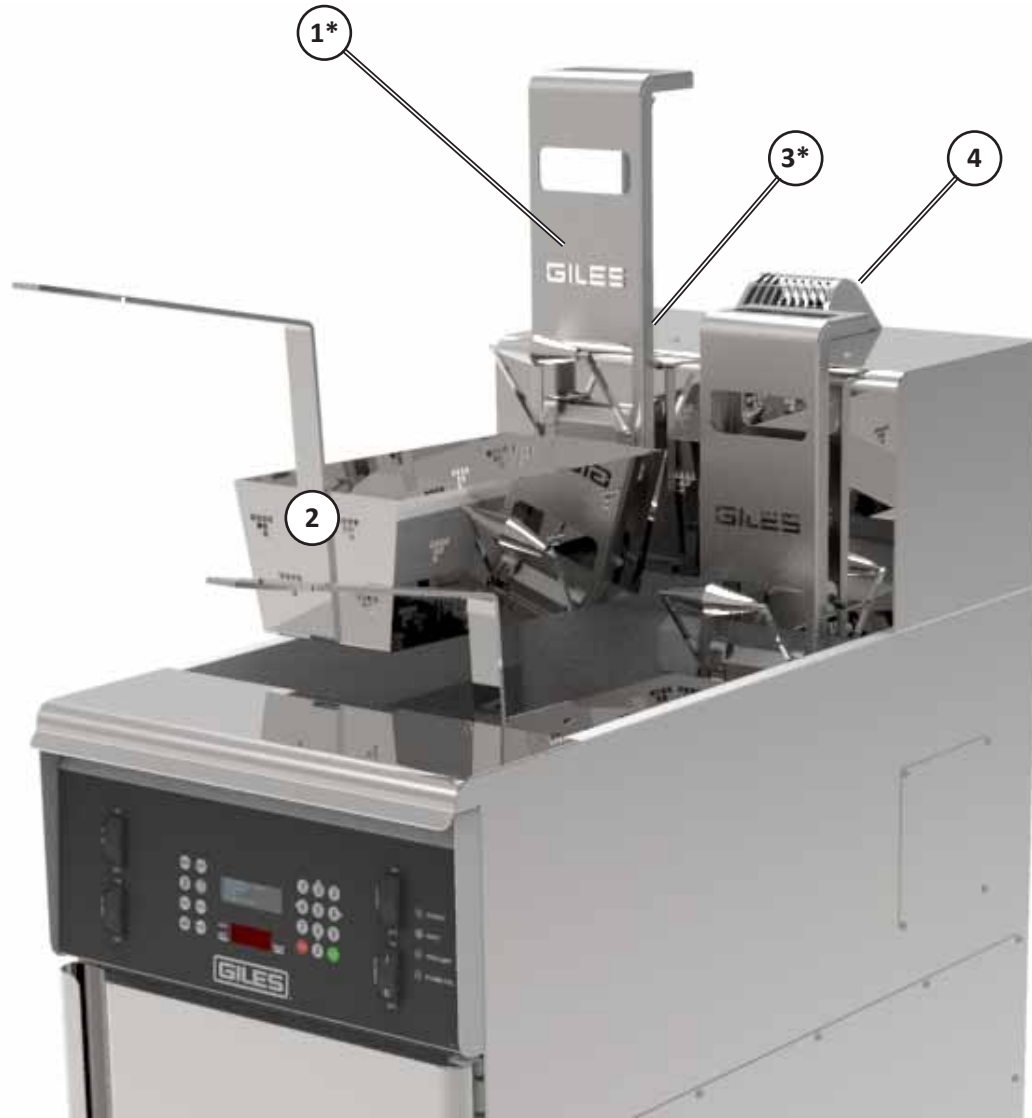



* Optional Feature

3.4 Basket & Optional Elevator Assembly



Item	Description	Function
1*	Basket Carrier (2) <i>Optional</i>	Holds cook basket in proper position as it is lowered & raised by the auto-basket lift. Easily removeable for cleaning. <i>Manual basket hanger rack on back header is standard without basket lifts.</i>
2	Cook Basket (2)	Contains product while cooking. Front spring handle for easier handling.
3*	Auto-Basket Lifts (2) <i>Optional</i>	Computer controlled ... automatically lowers cook basket into hot oil & raises cooked product out of the oil at end of cooking time. Helps avoid over-cooking. <i>Located inside rear of cabinet.</i>
4	Flue Gas Exhaust Outlet	Exhausts burner combustion gases from the fryer. These gases pose potential inhalation hazards due to CO & CO ₂ . The operating area must have adequate ventilation to the outside for removing harmful gases. <i>The outlet guard will become very HOT during operations ... use due CAUTION in the vicinity of the exhaust port.</i>

* Optional Feature

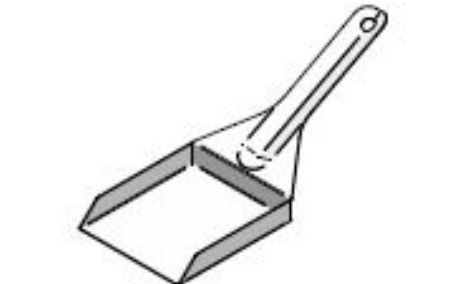

3.5 Accessories Included

Part	Description/Part Number	Function
	<p>Kettle Drain Brush P/N 71025</p>	<p>Use to clean fryer Vat Drain & surfaces of the heat exchanger.</p>
	<p>Stirring Utensil P/N 77775</p>	<p>Use to stir cooking oil & product in the vat as it is cooked to prevent sticking.</p>
	<p>Utility/Pot Brush P/N 71100</p>	<p>Heat-resistant brush for cleaning fry vat sides / bottom & surfaces of the heat exchanger.</p>
	<p>Crumb Shovel P/N 30059</p>	<p>Use to remove filter sediment from filter pan after filter cycle is complete.</p>

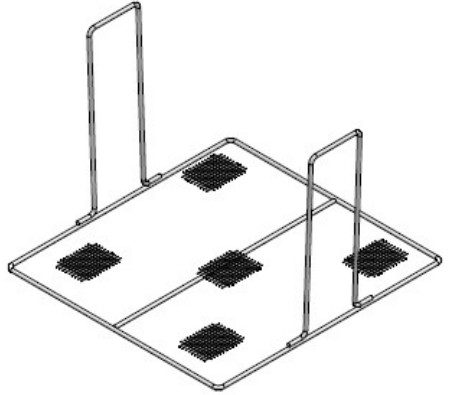
3.5 Accessories Included

Part	Description/Part Number	Function
	<p>L-Tip Round Bristle Brush, P/N 93609</p>	<p>Use to clean the underside & hard to reach surfaces of the heat exchanger & cook vat.</p>
	<p>Waste Oil Discharge Hose Assembly P/N 33667</p>	<p>Connects to fryer filter pump system. Used for removing waste cooking oil from fryer for disposal.</p> <p><u>NOTE: DO NOT USE TO WASH DOWN THE FRYER VAT!</u></p>
	<p>Vat Crumb Screen P/N 41622</p>	<p>Sits inside vat, serves as support for cook baskets if basket lifts are not used.</p> <p>Helps prevent excessive accumulation of crumbs & cooking residue in vat bottom around heat exchanger.</p> <p>Lifts out for cleaning.</p>

3.6 Accessories Not Included

Part	Description/Part Number	Function
	<p>Giles Filter Paper P/N 60819</p>	<p>Paper filter media place in filter pan for filtering cooking oil.</p>
	<p>Giles Filter Powder P/N 72004</p>	<p>Filter aid compound used when filtering cooking oil ... helps recondition oil by removing soluble fats & impurities.</p>
	<p>Giles Fryer Boil-Out P/N 72003 Case of (24) pre-measured 6-oz Packets</p>	<p>Fryer cleaner/degreaser ... add to water for a fryer boil-out cleaning procedure. Typical fryer requires (2) packets. Can also be used as an overnight cleaning soak. Also, ideal to clean tile & concrete floors.</p>

3.6 Accessories Not Included

Part	Description/Part Number	Function
 A white, rectangular metal oil caddy with a single black wheel on the left side. It features a blue handle on top and a yellow hose connected to a blue filter assembly on the right side.	Giles Oil Caddy P/N 79187	Portable waste oil disposal container with capacity for 80-lbs of waste oil. Intended to handle warm, clean, filtered oil ... no crumbs or debris.

4. Fryer Operation

This section describes operating procedures for *Giles Model GBF-80G Gas Fryers*.

DANGER

- Turn off fryer **POWER** switch & supply power at the main circuit breaker panel, or remove plug for wall receptacle before cleaning or performing maintenance.
- **DO NOT** wash down the fryer interior or exterior with water from a spray hose, or any other pressurized washing equipment.
- **DO NOT** operate this, or any other gas burning appliance, in an enclosed space without proper ventilation & a means of effectively venting combustion gases to the outside atmosphere.
- Failure to comply with **DANGER** notices will result in serious injury, even death, damage to equipment or property and void the factory warranty.

WARNING

- **DO NOT** use or store flammable liquids, or materials that produce flammable vapors, in the vicinity of this or any other appliance!
- **DO NOT (or ALLOW OTHERS to) for any reason, stand or step onto the top of the appliance.** Cooking oil in fryers can be **EXTREMELY HOT (excess of 330°F [166°C])** & bodily contact will cause extremely serious injury. Lids used to sometimes cover cooking vats/pots are not designed to, and **WILL NOT**, support the weight of a person. 
- Failure to comply with **WARNING** notices could result in serious injury, even death; damage to equipment and/or property and will void the factory warranty.

CAUTION

- Be sure the appliance is positioned in a stable, safe location with the caster wheel brakes in the locked position.
- Consult an electrician to be certain that all electrical specifications have been met & the unit is properly grounded in compliance with all codes. A wiring diagram is provided with the unit to aid an electrician.
- Due to the high temperature of cooking oil during cooking, it is extremely important that personnel exercise due caution when operating this equipment to avoid personal injury ... **thermal protection (gloves or mitts) should be worn while tended the appliance.**
- This appliance is not intended to be used by persons (including children) with reduced physical, sensory, or mental capabilities, or a lack of necessary experience & knowledge, unless they have been given adequate instruction and/or supervision concerning its use by a person responsible for their safety. Keep children away from the appliance.

4.1 Computer Cooking Controller

This section explains the functions, features & operational procedures for the *dual-timer Computer Controller*. The controller has been designed to be user-friendly & many operational instructions & prompts will be shown on the *upper display screen* (blue graphic) to help guide you through each process.



4.1.1 Keypad & Function Keys



Numeric Keypad: Use to enter fryer setting values & to create/edit *Menu Item cooking presets*.

Arrow Keys: [2 - 4 - 6 - 8] keys on keypad are also used as [ARROW KEYS] to operate *Basket Lifts (if installed)*, select various items, navigate lists, move a cursor, etc. [2 - 8] for UP/DOWN ... [4 - 6] for LEFT/RIGHT. The keys illuminate to indicate when active.

[START]: A function key used for various operations ... start cook cycles, select items, save settings, etc.

[CLEAR]: A function key used to cancel cook cycles, exit functions, etc.

4.1.1 Keypad & Function Keys - continued



MENU Key: Action key which is pressed in combination with other keys to access programmed menu presets. Fifty (50) different Menu Item cooking presets can be programmed.



EDIT Key: This is an action key which is pressed in combination with other keys to enter edit mode for changing or creating Menu preset settings.



TEMP Key: Press this key to input a cooking oil temperature setpoint. When fryer is in **READY** state, pressing key twice (2x) will display *actual oil temperature* on the *lower display screen* for approximately **20 secs**. **NOTE:** During **PREHEAT**, the real-time actual temperature is displayed.



CLOCK Key: Press this key to begin manually setting a cooking time (mm:ss).



Press this key during **PREHEAT** to enter the **BOIL OUT** program. Temperature setpoint and cook time changes to **BOIL TEMP** and **BOIL OUT TIME** as specified in **User Settings (Section 4.1.8, Access & Edit User Settings)**. **Default = 200°F & 30 minutes.**



Press this key to enter **COOL** mode. Energy-saving feature, allows Fryer to idle at a lower temperature during inactive periods. Temperature setpoint changes to the **COOL TEMP** specified in **User Settings (Section 4.1.8, Access & Edit User Settings)**. **Default setting = 275°F.**



ALARM Reset Key: Pressing this key silences the Controller alarm and acknowledges certain status messages.



BASKET Key: Activates arrow keys [2 - 4 - 6 - 8] for manually operating basket lifts. The key is disabled during **PREHEAT** to prevent lowering food products into oil that is not at proper cooking temperature. **The key is inactive in fryers without the Basket Lift Option.**



Upper Display (OLED, blue graphic): Displays menu item presets, fryer status information and various operator instructions & prompts.



Lower Display (7-segment, red graphic): Displays cook time countdown, actual oil temp or setpoint, error codes & various status messages.

Indicators: [HEAT] illuminates to indicate that controller is calling for fryer heat to energize. [LEFT TIMER / RIGHT TIMER] indicators illuminate to show which side's timer is active in the display.

4.1.2 Controller - General Overview

The following is general operational information only. Detailed procedures and instructions are discussed in later sections. During operation, instructions and prompts will be shown on the *upper display screen* to help guide you through certain processes. Additionally, some controller keys and indicator lights will illuminate as a further aid.

- **POWER UP:**

Place **POWER** switch in **[ON]** position. Controller will power up and sound an alarm. The message **“POWER FAILURE [PRESS START TO PREHEAT]”** is shown on the *upper display screen*. ***This is normal***, intended to prevent the fryer from beginning to heat while unattended, such as after power interruptions. Pressing the **[START]** key silences the alarm and places fryer into **PREHEAT** mode. If **HEAT** switch is in the **[HEAT]** position, and temperature setpoint is higher than the current actual oil temperature, heating elements will turn ON and cooking oil will begin to heat.

CAUTION! DO NOT place HEAT switch in [HEAT] position unless vat is filled to the FULL level with cooking oil (or water).



- **PREHEAT:**

Oil is heating ... real-time actual oil temperature will be displayed on the *lower display screen*. When oil reaches the programmed setpoint, the alarm will sound and *upper screen* will display the message **“ALARM - STIR OIL”**. At this time, press the **[ALARM]** key & vigorously stir cooking oil. Controller will go into a 10 second delay ... the oil temperature will typically drop when stirred & if it falls enough below setpoint during this delay time, **PREHEAT** continues until it returns to setpoint. ***This process helps to ensure more consistent temperature throughout the total volume of oil, which results in better cooking performance.*** Upon returning to setpoint, alarm sounds again & *upper screen* reads **“ALARM - SETPOINT REACHED”**. Pressing the **[ALARM]** key will place fryer into **READY** state.

- **READY STATE:**

Fryer is ready for cooking. The *lower controller screen* changes to display the current controller temperature setpoint. The last cook settings used will be shown on the *upper display*.

While fryer is in either **PREHEAT** or **READY** state, you may change cook settings either by selecting a different *menu item preset*, see [Section 4.1.5.2, Selecting a Menu Preset](#) • **OR** • manually inputting different settings (time and/or temp), see [Section 4.1.3, Setting the Cooking Temperature](#) & [Section 4.1.4, Manually Setting the Cook Time](#).

NOTE: If PASSCODE ENABLE is set to ON, you cannot manually set a different cook time without entering the proper password. This lockout feature provides management control of cooking procedures.

- **START:**

The current cook time setting for each vat side is shown on the *upper display*. To start a cooking cycle press the **[START]** key + select side: **[4]=Left, [6]=Right, [5]=Both**. When the selected timer starts, a cook time countdown appears on the *lower display*.



+



+

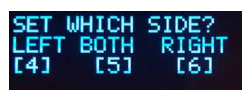

4.1.3 Setting the Cooking Temperature

The cooking temperature setpoint *must always* be manually entered ... the programmable ***Menu Item presets do not include a cooking temperature settings.***

Instructional prompts will be shown on the *upper display* to help guide you.

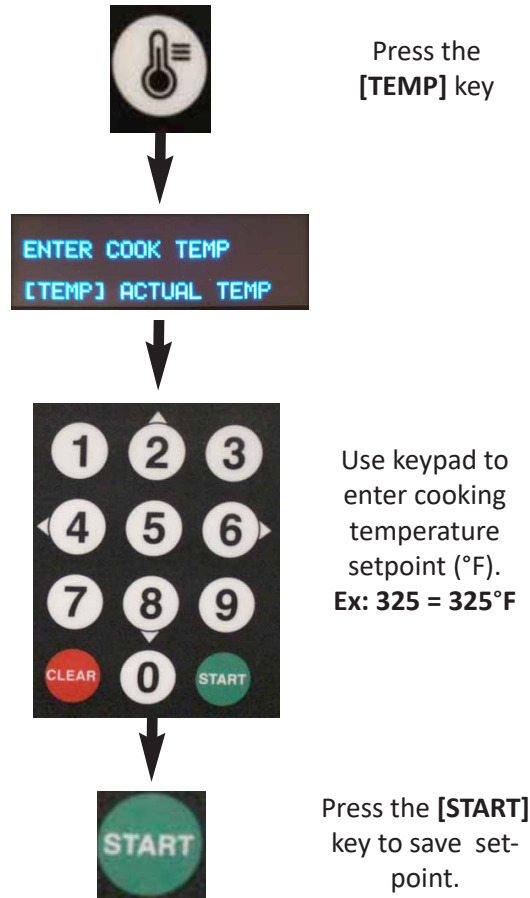

WARNING As a precaution, **ALWAYS KEEP** the control panel **HEAT** switch in **OFF** position unless vat is filled to **[FULL]** level with cooking oil, or water.

- If actual oil temperature is lower than the entered setpoint, controller will immediately enter **PREHEAT** (*small red HEAT indicator beside lower display screen turns ON*) when setpoint is saved. Oil does not actually begin heating, until the control panel **HEAT** switch is placed in **ON**. The amber control panel **HEAT** indicator light will turn **ON**, burners ignite & oil begins heating.
- If actual oil temperature is **equal to or hotter than** the entered setpoint, an alarm sounds & message **"SETPOINT REACHED"** is displayed on *upper screen*. Press the **[ALARM]** key ... fryer enters **READY** state & is ready to cook.

While heating, real-time actual oil temperature is shown on the *lower display screen*. After setpoint is reached, the display will change to show setpoint temperature instead of actual.

NOTE:

Pressing the **[TEMP]** key twice (2x) will display actual temperature for 20 seconds.

The default measurement unit for temperature is **[°F]** ... it can be changed in *Section 4.1.8, Controller User Settings*.

4.1.4 Manually Setting the Cook Time

On occasion you may wish to enter a cook time manually, rather than use one of the *programmed menu item presets*. To input cooking time manually, follow the process below.

IMPORTANT! If the *user setting* **PASSCODE ENABLE** is set **ON**, you **cannot** input a cooking time unless you first enter a proper password. You may still choose a cooking preset from the programmed selections, see *Section 4.1.5*.

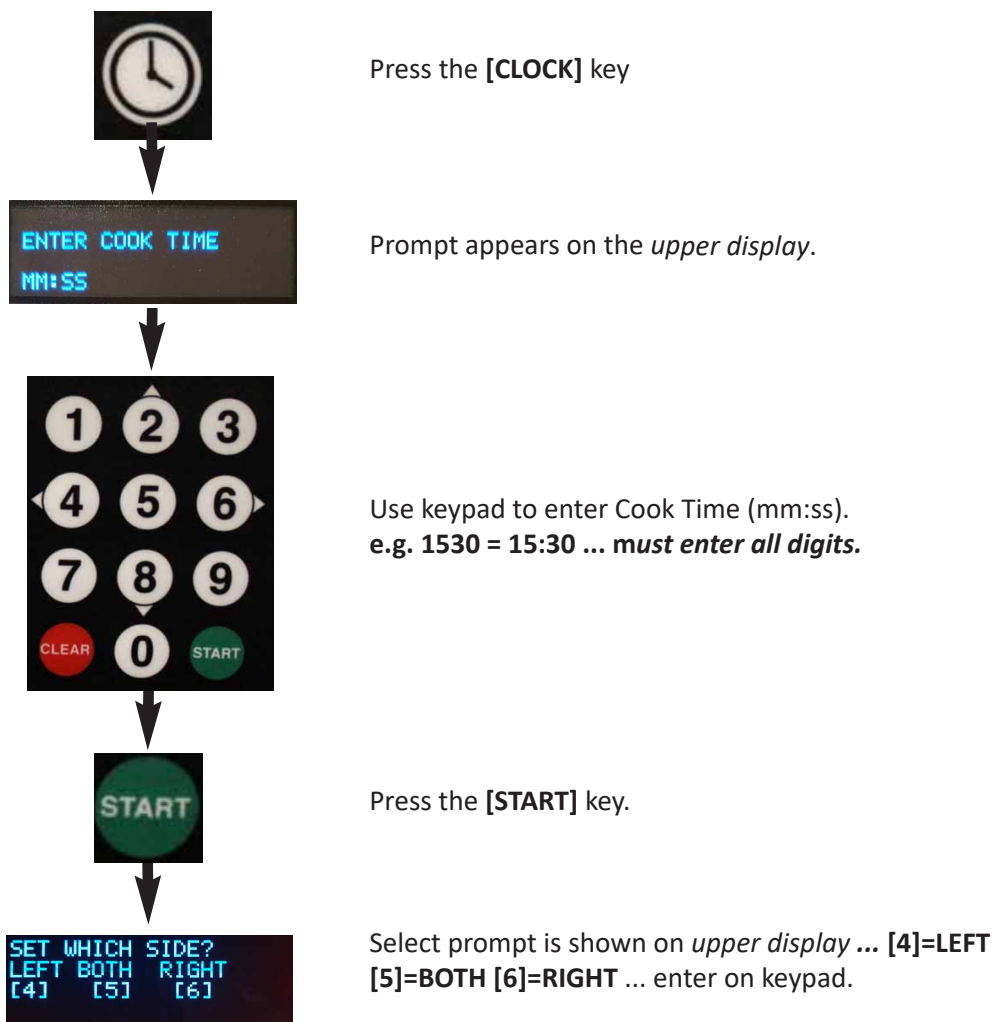

If needed, repeat process to set a Time for the other side.

NOTE: *Menu Item Presets* include a *Product Name* which is displayed on the *upper screen* when preset is selected. When a cooking time is manually input the name displayed will be shown as **"MANUAL"**.



4.1.5 Working with Menu Item Presets

NOTE:

Cooking presets stored in the controller **do not** include a cooking temperature setting. Temp must always be input manually before cooking begins, see *Section 4.1.3*.

Fifty (50) **Menu Item Preset** cook settings are stored in the controller. Each includes:

- **Menu #** - Sequential ID number
- **Menu Name** - Name of the food product assigned to the preset.
- **Cooking Time** - Time setting for cooking the product.
- **STIR OVERRIDE** - For the menu item, the setting overrides the controller’s general **STIR ALARM** setting specified in *user settings* . **Factory default is [NORMAL]**.
- **FISH FILTER** - For the menu item, to prevent flavor transfer, establishments cooking seafood products may wish to force associates to filter oil after cooking only **one (1) batch** of the item. The setting overrides the controller’s general **FORCE FILTER** setting specified in *user settings*. **Factory default is [OFF]**. A **SNOOZE** feature is available that will allow **two (2) batches** to be cooked before forced filtering.

All the menu item presets are factory-programmed with default settings. The first ten (10) are set up for some popular menu offerings, as shown below. All others contain the general settings shown on the last line of the table. You can edit any of these presets to customize them for your specific needs.

MENU NO.	MENU NAME	TIME (MM:SS)	STIR OVERRIDE	FISH FILTER
1	BONE-IN-CHICKEN	13:00	NORMAL	OFF
2	TENDERS	7:00	NORMAL	OFF
3	WEDGES	6:00	NORMAL	OFF
4	BONE-IN-WINGS	8:00	NORMAL	OFF
5	BONELESS WINGS	7:00	NORMAL	OFF
6	POPCORN CHICKEN	3:00	NORMAL	OFF
7	LIVERS	4:00	NORMAL	OFF
8	CORNDOGS	10:00	NORMAL	OFF
9	CHEESE STICKS	3:00	NORMAL	OFF
10	FISH	3:00	NORMAL	OFF
11 thru 50	MENU XX	2:00	NORMAL	OFF

Details for working with **Menu Item Presets** are explained in the following sections.

4.1.5.1 Editing a Menu Item Preset

To edit a *Menu Item* cooking preset, follow the steps as outlined on the following pages.



To begin, press the controller's **MENU** function key twice (2x).

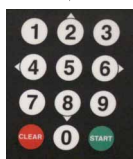

Use numeric keypad **[2] UP** - **[8] DOWN** to scroll through the list of items until *Menu No.* you desire to edit appears on the *upper display*.



Press the **[EDIT]** function key to select menu item for editing. **DO NOT** press **[START]** as prompted on screen.



Use arrow keys **[2 - 8]** to move the cursor **[-->]** until it points to the specific setting item you wish to edit:

- [NAME]**
- [TIME]**
- [STIR OVERRIDE]**
- [FISH FILTER]**



Press the **[START]** key to begin editing that setting.

NOTE: *Cooking temperature* cannot be preset. It must always be manually input, see [Section 4.1.3, Setting the Cooking Temperature](#).

4.1.5.1 Editing a Menu Item Preset - continued

A. Edit MENU NAME:

There are two different methods which may be used to edit the *Menu Item Name* when selected for editing.

Method 1: Input NAME letter by letter.



- Select **NAME** for editing as shown on previous page.
- A flashing cursor appears at the 1st letter of the current **NAME**.
- Use numeric keypad **[2] UP** - **[8] DOWN** to scroll through alphabet ... the character above cursor position will change.
- Stop scrolling when desired letter appears.
- Use numeric keypad **[6] RIGHT** to move cursor to next letter in **NAME** & repeat. Keypad **[4] LEFT** can be used to backspace if needed.

When finished editing, press **[START]** to **Save**

- OR -

Press **[CLEAR]** to **Cancel & Exit** without saving



Method 2: Select a NAME from Catalog of pre-programmed names.

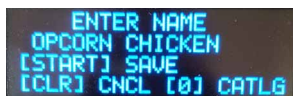

- Select **NAME** for editing as shown on previous page.
- A flashing cursor appears at the 1st letter of the current **NAME**.
- Press keypad **[0]** to open a *catalog* of pre-programmed *Menu Names*.
- Use numeric keypad **[2] UP** & **[8] DOWN** to scroll through the list of names ... stop when desired **NAME** appears in *upper display*.
- Press **[START]** to copy this **NAME** into the *Menu Item* being edited & return to previous display.

After selecting **NAME**, press **[START]** to **Save**

- OR -

Press **[CLEAR]** to **Cancel & Exit** without saving

- OR -

Press **[0]** to re-open the *catalog* of names.



Pressing **[CLEAR]** twice (2x) will **exit** from **Editing**.



4.1.5.1 Editing a Menu Item Preset - continued

B. Edit COOKING TIME:

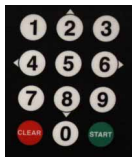

- Select **TIME** for editing as shown on *page 42*.
- *Upper display* shows current **TIME** setting & the prompt “*Enter New Time*” appears.
- Use numeric keypad to enter a new **TIME (mm:ss)**. *All digits must be entered, e.g. 500 for 5:00 (5 mins ... 00 secs)*.
- While inputting value, pressing [**CLEAR**] will backspace & erase incorrect entry.

When finished editing, press [**START**] to **Save**

- OR -

Press [**CLEAR**] to **Cancel & Exit** without saving



Pressing [**CLEAR**] twice (2x) will **Exit** from **Editing**.



C. Edit STIR OVERRIDE Setting:

Regardless of the controller’s general **STIR ALARM** setting (*User Settings, Section 4.1.8*), you may wish to either have a menu item stirred or not stirred while cooking. **STIR OVERRIDE** overrides the general setting for the specific menu item. Available settings are [**NORMAL**] • [**SKIP**] • [**FORCE**].

[**NORMAL**]: Alarm is issued as specified.

[**SKIP**]: Alarm is **NOT** issued for this item, regardless of the controller’s general setting.

[**FORCE**]: Alarm is **ALWAYS** issued for this item, regardless of the controller’s general setting.

Factory-default is [**NORMAL**].

To edit **STIR OVERRIDE** setting, scroll to & select as described previously ... [—>] points to [**STIR**]



Press the [**START**] key to toggle between the available options ... stop at desired setting.

4.1.5.1 Editing a Menu Item Preset - continued

D. Edit FISH FILTER Setting:

To minimize potential for flavor transfer, establishments that cook seafood in the same fryer as other foods may wish to force operators to filter oil after cooking only ***one (1) batch*** of a particular food item. When **FISH FILTER** is set **ON**, the unit will enter **FILTER MODE** after cooking one load of the specific item. If **FORCE FILTER SNOOZE** is set **ON** (*User Settings, Section 4.1.8*), an additional load may be cooked before filtering is forced. When **FORCE FILTER** is **OFF** only a ***filter warning message*** is displayed on the *upper controller screen*.

When **FORCE FILTER** is **ON**, the fryer is *locked out* until oil is properly filtered.

To edit **FISH FILTER** setting, scroll to & select **[FISH FLTR]** as described previously ... **[←>]** points to **[FISH FLTR]**



Press the **[START]** key to toggle between the selections ... stop at choice.

4.1.5.2 Selecting a Menu Item Preset for Cooking

A. Direct Entry Method - desired *Menu* is known.

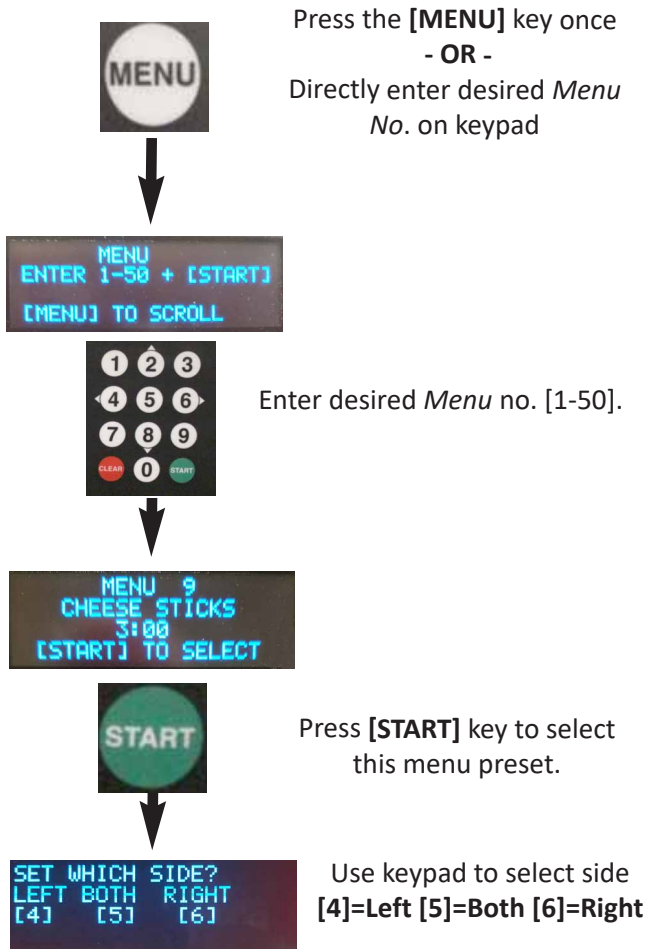

B. Scroll Method - Scroll through list of *Menu Presets*. Settings are shown on the *upper display*.

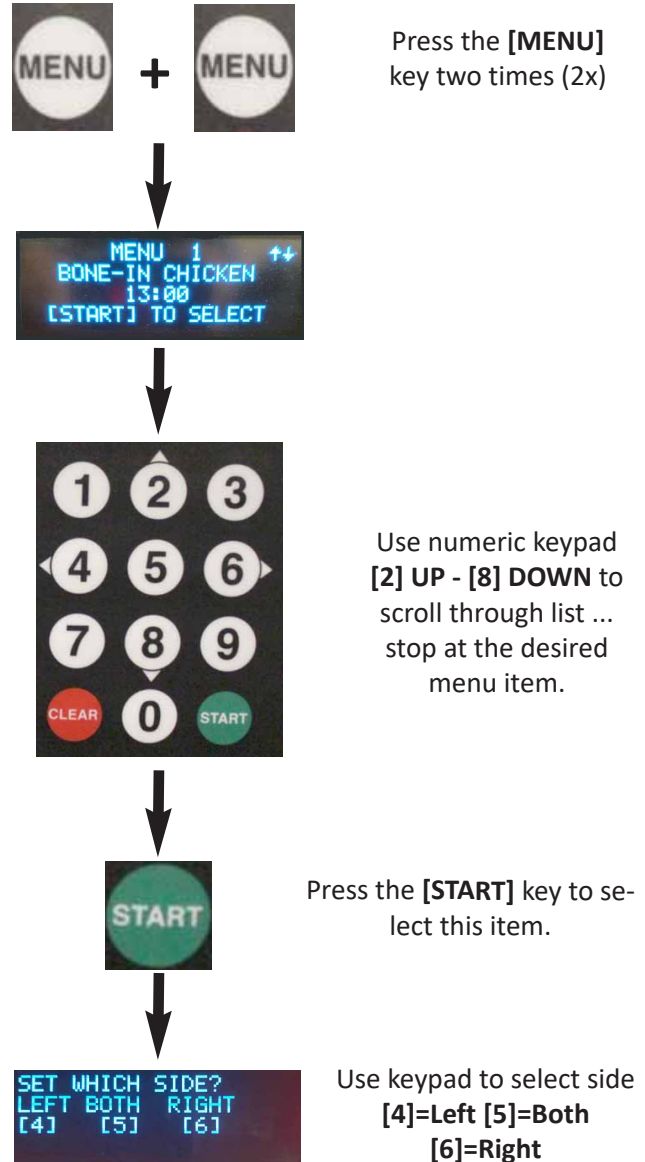

NOTE:

- If the controller user setting “**COOK ON MENU SELECT**” is set **ON** & fryer is in **READY** state, it will automatically enter **COOK** mode as soon as the side is selected ... cooking time begins counting down on *lower display*.
- If this setting is **OFF** (*default*), the cooking cycle must be started as explained in *Section 4.1.6*.

4.1.6 Cooking Cycle General Overview

READY 335°F
TENDERS | WEDGES
07:00 | 06:00
[START] TO COOK

COOKING TEMPERATURE, MENU NAME, COOK TIME, STIR OVERRIDE & FISH FILTER settings are shown on the *upper display*. **READY** message indicates that cooking oil is at proper temperature & fryer is ready for cooking.

325°F

When in **READY** state, temperature setpoint is shown on *lower display*.



After selecting a *menu item preset*, or manually entering a *cooking time*, start the cooking cycle by pressing the **[START]** key once.

SET WHICH SIDE?
LEFT BOTH RIGHT
[4] [5] [6]

You are then prompted to select basket side. Either or both can be selected by pressing the appropriate key for your choice.

When side is selected, controller enters **COOK** state ...

NOTE: Fryer will not enter COOK unless it is in READY state.

If fryer is equipped with automatic basket lifts & they are *enabled*, the basket(s) will be lowered into cooking oil & programmed cooking time will begin counting down on the *lower display*. If lifts are not installed (*or not enabled*), you must manually place basket(s) into oil, resting on the support screen in vat bottom.

The *upper display* indicates the side that is cooking, and displays the temperature setpoint. **Timer Indicators** beside the *lower display screen* will indicate which timer is displayed.

COOKING LEFT 75°F
BONE-IN WITENDERS
08:00 | 07:00
[CLEAR] TO STOP

HEAT 07:30 RIGHT TIMER
LEFT TIMER



Two different *menu items* can be selected and started together as described in Section 4.01.5.2.

After selecting a second *menu item preset* (or entering different time), press the **[START]** key once again and when prompted (*there is now only one choice*), press the appropriate arrow key (**<4 or 6>**) to start the second timer. *Lower display* and *timer indicator* will change to show the second timer.

SET RIGHT?
[>] RIGHT
[CLEAR] CANCEL



x 2

When both timers are running, pressing the **[TIME]** key 2 times will toggle *lower display* between timers.

4.1.6 Cooking Cycle General Overview - continued

STIR ALARM: When enabled, the alarm sounds & a display prompt is issued at a specified time during the cooking cycle, to notify operator that it is time to gently stir the cooking product. Stirring helps to promote thorough cooking & prevent pieces from sticking together. The feature must be enabled in *User Settings, Section 4.1.8* & the [%] of cycle parameter must be set. **STIR ALARM %** is the amount of elapsed cook time before the alarm sounds. e.g. [STIR ALARM %] = **60**, then during a **10 min.** cook cycle, the alarm will sound after **6 mins.** of cooking have elapsed.

Factory default: **STIR ALARM ENABLE** is **ON** • **STIR ALARM %** = **62**.

A menu item **STIR OVERRIDE** setting can override the **STIR ALARM ENABLE** setting, see *Section 4.1.5.1*.

When the cooking cycle time is complete, an alarm will sound & a message **“DONE COOKING - (LEFT) (RIGHT) or (BOTH)”** is displayed, as appropriate. If fryer is equipped with basket lifts, basket is automatically raised from the oil. Press **[ALARM]** key to silence alarm & fryer re-enters **READY** state, awaiting the next load of product.



x 2

To cancel a running cook cycle press the **[CLEAR]** key once, then press it again to cancel - **OR** - press **[<4]** to continue cooking.

4.1.7 Other Controller Features

4.1.7.1 Manually Operating Optional Basket Lifts (if equipped)



Press the **[BASKET]** Key once



Use keypad **[#2] UP** & **[#8] DOWN** keys to select **Raise** or **Lower** Lift

- OR -

Press **[CLEAR]** to Cancel the operation.

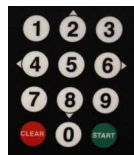

Use Keypad to select side **[4]=Left** **[5]=Both** **[6]=Right**, when selected, Lift raises or lowers

NOTE:

- **LIFT switch on control panel must be in the ON position.**
- As a safeguard against placing product into oil that is not at the proper cooking temperature, manual operation of lifts is disabled while fryer is in **PREHEAT** mode.
- After a basket lift completes an operating cycle, it cannot be actuated again until the small red indicator above the **BASKET** key turns **OFF**, approximately **20 seconds**.

4.1.7.2 COOL Mode



COOL Mode is an energy-saving feature that lowers the oil temperature setpoint value, placing fryer into a standby state during periods of inactivity. Can also help slow oil oxidation, extend oil durability & life.

To enter, press the [**COOL**] function key once. Temperature setpoint changes to the **COOL TEMP** setting specified in *User Settings, see Section 4.1.8*.

Factory-set default is 275°F. Setting can be edited in the range of **200° to 350°F**.



+



To exit **COOL Mode** press the [**CLEAR**] key, then press [**<4**] to exit

- OR -

Press [**CLEAR**] again to continue **COOL Mode**.

Upon exit, the temperature setpoint will return to the previous active value & fryer enters **PREHEAT** mode until temperature setpoint is reached again.

4.1.7.3 AUTO-COOL Feature

When the **AUTO-COOL** feature is turned **ON**, the fryer automatically enters **COOL Mode** when *no cooking cycles are started* within the amount of time specified by the **AUTOCOOL TIME** setting. See *Section 4.1.8, User Settings*. **Factory-default is [OFF] & AUTOCOOL TIME = 30.** Setting can be enabled/edited in the range of **1 to 510 mins**.

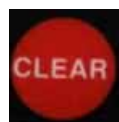

+



To exit **COOL Mode** press the [**CLEAR**] key, then press [**<4**] to exit

- OR -

Press [**CLEAR**] again to continue **COOL Mode**.

Upon exit, the temperature setpoint will return to the previous active value & fryer enters **PREHEAT** mode until temperature returns to setpoint.

4.1.7.4 BOIL OUT Mode



Pressing the [**BOIL**] function key while controller is in **PREHEAT** places fryer into **BOIL OUT Mode**.

Temperature & time change to the **BOIL TEMP** & **BOIL OUT TIME**, respectively, specified in *User Settings, see Section 5.1.8*. **Factory-default: BOIL TEMP = 200°F & BOIL OUT TIME = 30 minutes.** **BOIL TEMP** can be edited within the range of **185° to 208°F ... BOIL OUT TIME** can be set in the range of **1 to 45 minutes**.

IMPORTANT!

After BOIL OUT MODE is completed, the controller automatically resets the temperature setpoint to 50°F. It must be reset to a proper cooking temperature before the fryer will heat cooking oil for normal operation.

Fryer must be properly drained, rinsed and prepared for cooking after a Boil Out cycle. See Section 6, Cleaning.

4.1.8 Controller User Settings

To access the User Settings menu for editing ...

Press [TIME] key



Enter on keypad

9 9 9 9

Press [START] key

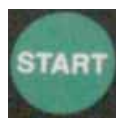

The table below details of available User Settings & factory-set Defaults.



- Use keypad [4] & [6] (left/right) to scroll through the available settings ... current setting value is shown on the *upper controller display*.
- When desired setting to edit is displayed, press the [EDIT] key.



- Use keys [2] & [8] (up/down) to change the set value. Press [EDIT] key again to *SAVE*.

To exit *User Settings* menu, press the [CLEAR] key.

NOTE:

The message **“TOO LOW”** or **“TOO HIGH”** is displayed if an entered value is outside of the allowable range & will cause a controller error.

NAME	DESCRIPTION	RANGE	DEFAULT
TEMP SCALE	Temperature unit of measure	°F or °C	°F
FORCE FILTER	When ON , forces operator to filter oil after the number of cook cycles set by FILTER COUNT are completed ... locks-out fryer until filtering is completed.	ON - OFF	ON
FORCE FILTER SNOOZE	When ON , allows (1) additional cook cycle after FILTER COUNT is exceeded ... (<i>active only when FORCE FILTER is ON</i>).	ON -OFF	OFF
FILTER COUNT	Number of cook cycles before filtering is required.	1 to 20	4
GUARD BAND	Cooking not allowed if oil temperature deviates from the setpoint by amount of guard band	1 to 990	900
MAX SETPOINT	Maximum oil setpoint allowed by controller.	32°F to 375°F	350°
AUTOCOOL	After a specified amount of time, unit will enter COOL mode.	ON - OFF	OFF
AUTOCOOL TIME (MINUTES)	When AUTOCOOL is ON , fryer automatically enters COOL mode after unit is idle for this amount of time.	1 to 510 minutes	30
AUDIBLE ALARM (SECONDS)	Duration of the audible alarm in seconds ... tone automatically silences after this amount of time..	5 to 120 seconds	10
COOL TEMP	Temperature setting for COOL mode	200°F to 350°F	275°F
BOIL TEMP	Temperature setting for the BOIL OUT cycle	185°F to 208°F	200°F
FILTER RESET	The temperature that resets fryer to exit FILTER MODE .	200°F to 325°F	290°F
BOIL OUT TIME	Time (in minutes) for the BOIL OUT cleaning cycle	1 to 45 minutes	30
STIR ALARM ENABLE	If ON , the STIR ALARM is issued after a specified % of cook cycle has elapsed.	ON - OFF	ON
STIR ALARM %	When STIR ALARM is ON , the alarm sounds after this percent [%] of cooking cycle has elapsed.	10% to 90%	62%
KEY BEEP ENABLE	If ON , an audible sound is generated with each keystroke.	ON - OFF	OFF

4.1.8 Controller User Settings

NAME	DESCRIPTION	RANGE	DEFAULT
LANGUAGE	Sets the controller's displayed language	English-Spanish-French	English
COOK ON MENU SELECT*	When ON , selecting a MENU NO. for cooking will automatically begin the cook timer. <i>Reduces the number of keystrokes needed to start a cook cycle.</i>	ON - OFF	OFF
[0] KEY EXTRA TIME	When ON , operator can add extra cook time <i>either after or during the cycle</i> by pressing [0] + the number of mins.	ON - OFF	OFF

* Available **ONLY** on dual-timer controllers.

4.1.9 Password Security

It is possible to add **PASSWORD** security for certain controller activities. This feature is a **FACTORY SETTING** that is typically **DISABLED** on new equipment. When **PASSCODE ENABLE** is set to **ON**, you are prompted to enter a password before you can perform many controller operations. Improves management control over cooking operations.

If you desire to have password security enabled, or have questions concerning this feature, call **Giles Technical Services** at **800.554.4537** to request the passcode & receive instructions as to how to enable the feature.

4.1.10 Start-up Procedure

- Initially, verify that the **HEAT** switch **(1)** is **OFF**.
- Place the **POWER** switch **(2)** in **ON** position. The green **POWER** light **(3)** will turn **ON**, computer controller will power-up & then sound an alarm tone. The message "**POWER FAILURE [PRESS START TO PREHEAT]**" is shown on the upper display screen **(4)**. **This is normal**, intended to prevent the fryer from beginning to heat after a loss of power until attended by an operator. Press the **[START]** key **(5)** to silence the alarm & place fryer into **PREHEAT** state. The last used cook settings are shown on the upper display. Controller indicates that the fryer is heating, but until the **HEAT** switch **(1)** is placed in **ON**, the burners will not ignite to begin heating oil. **DO NOT** place **HEAT** switch in **ON** position until the fry vat has been filled to the **[FULL]** level mark with either cooking oil or water.
- See Section 4.2, Cooking Procedures.



4.1.11 Controller Errors & Alarms

When conditions occur that will cause unsafe operation or possible damage to the unit (*drain open, low oil level, high temp, etc.*), the controller halts fryer operation, activates an alarm & displays an error code & message. The error code is shown on the *Lower display screen (red graphic)* ... the error message / prompt is shown on the *Upper display screen (blue graphic)*. Generally, fryer heat is shut-down until the error condition has been corrected. Pressing the **[ALARM]** key silences the alarm, but **does not** clear the error. Programmed *error codes* are described in the table below ... further details are presented in the following section.

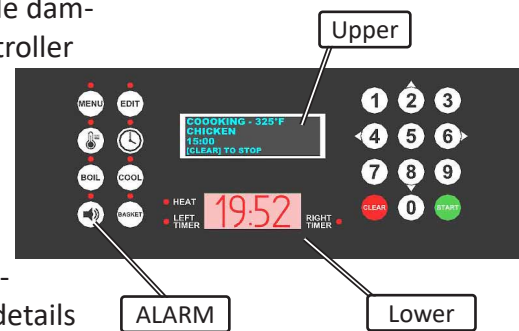

ERROR CODE	DESCRIPTION (OLED Display)	PROBLEM
OPEN	DRAIN IS OPEN	Drain valve is open, or not completely closed. If equipped w/basket lifts, baskets will be raised if cooking.
----	CHECK OIL LEVEL, ENSURE VAT IS FULL, IF FULL THEN PRESS [START]	This is a secondary prompt notifying to confirm oil level ... it is displayed after the <i>OPEN</i> drain error has been cleared.
ER03	LOW OIL LEVEL – ENSURE VAT IS FULL (Element/Add Level Differential Warning)	The oil level is below the [ADD] line in the vat. Add fresh oil until level is at [FULL] mark & stir. Error remains in effect until temperature differential is cleared.
ER06	LOW OIL LEVEL – ENSURE VAT IS FULL – PRESS [START] (Post ER03 Warning)	This is a secondary prompt notifying to confirm oil level ... it is displayed after <i>LOW OIL ER03</i> error is cleared ... fryer will not heat until START key is pressed.
ER07	MAX ELEMENT TEMP – PRESS [START] (Post Warning)	This is a secondary prompt displayed after <i>MAX ELEMENT TEMP ER19</i> error is cleared (heat exchanger has cooled sufficiently).
ER13	OIL PROBE Error	Problem with the variable oil temp sensor. Service required.
ER15	ELEMENT PROBE Error	Problem with the element temp sensor, mounted against the heat exchanger. Service required.
ER17	ADD LEVEL PROBE Error	Problem with the “Add Level” sensor located at vat [ADD] mark. Fryer without this sensor must have the ELMT-ADD ENABLE setting OFF in Factory Settings. Sensor cannot be bypassed. Service required.
ER19	MAX ELEMENT TEMP Error	The maximum heat exchanger temperature has been exceeded. This is a safety device; NEVER bypass this probe.
ER25	GUARD BAND EXCEEDED	Actual oil temperature deviates from setpoint by the Guard Band value. Allow oil to cool or heat to be within range. Factory default is 900°F ... Typically, this error should not occur.
ER37	EEPROM Error	An error occurred while saving settings to the EEPROM. Contact Giles Tech Service (800.554.4537).
ER38	Internal ADC Error	The ADC (Analog-to-Digital Converter) chip that reads output from thermocouples is not working. MCB1 board must be replaced. Contact Giles Tech Service (800.554.4537).

4.1.11.1 Resolving Controller Errors & Alarms

NOTE: When controller issues an error/alarm & halts operation while cooking, it may be necessary to discard any food products that was cooking at the time ... always comply with all local Standard Operating Procedures & Best Practices.

During the following steps, instructions indicating to press the **[ALARM]** key only silence the alarm tone ... pressing the key **DOES NOT** clear the error or reset fryer. The tone will stop automatically after about 10 secs.

- **OPEN: DRAIN OPEN** - If vat drain valve is opened (*even slightly*) while fryer power is **ON**, alarm sounds, *lower display screen reads OPEN, upper display screen reads "ERROR ALARM - DRAIN IS OPEN"*. Fryer heating is shutdown & remains **OFF** until the error is corrected.
Press **[ALARM]** key ... clear alarm by fully (*and tightly*) closing the drain valve. When closed, an alarm sounds again & *upper display reads "CHECK OIL LEVEL, ENSURE VAT IS FULL, IF FULL THEN PRESS [START]"*. This is a post-alarm notification, alerting the you to confirm that cooking oil is still at the **[FULL]** level. Add oil if needed, then press the **[START]** key to return to **PREHEAT** mode ... *Fryer will not heat until [START] is pressed.*
- **ER03: LOW OIL LEVEL** - Alarm sounds, *lower display shows Er03, upper display reads "ERROR ALARM - CHECK OIL LEVEL - ENSURE VAT IS FULL"*. Fryer heating is shutdown until the condition is corrected. The detected temp differential between a sensor at the **[ADD]** level & a sensor attached to the heat exchanger has exceeded an acceptable value, indicating *low oil level, which greatly increases the potential for a vat fire!* Press the **[ALARM]** key ... allow fryer to cool adequately in order to reset the fryer error condition. Add oil to raise level to the **[FULL]** mark, as needed.
- **ER06: LOW OIL LEVEL Post-error Warning** - After *Er03* has been cleared, another alarm sounds. The *lower display shows Er06, upper display reads "CHECK OIL LEVEL - ENSURE VAT IS FULL - PRESS [START]"*. This alarm notified you to verify that cooking oil is at the **[FULL]** level. If situation has been corrected, press **[START]** key to enter **PREHEAT** & proceed to continue cooking operations ... *Fryer will not heat until [START] is pressed.*
- **ER19: MAX. ELEMENT TEMP** - Temperature at surface of heat exchanger has exceeded the *maximum allowed* by the controller. Alarm sounds, *lower screen shows Er19, upper screen reads "ERROR ALARM - MAX ELEMENT TEMPERATURE"*. Fryer heating is shutdown. Press **[ALARM]** key ... heat exchanger surface must cool below the allowable temperature threshold to clear this error. Typical cause is that the heat exchanger has been exposed due to either low oil level or no oil. *False alarms can occur when preheating cold oil at beginning of the day ... regular stirring of oil while preheating will help avoid such occurrences.*
- **ER07: MAX ELEMENT TEMP Post-Error Warning** - After an *Er19* error has been cleared, a secondary notification alarm occurs. The *lower screen reads Er07, upper display reads "MAX ELEMENT TEMP - PRESS [START]"*. The alarm only notifies you that the *maximum element temperature error* occurred & is now cleared. Press **[START]** key to enter **PREHEAT** mode ... *Fryer will not heat until [START] is pressed.*

NOTE: If an error condition persist and cannot be resolved, it could be an indication of component failure or system malfunction. Please contact a factory-authorized service agent, or call 800.554.4537 for Giles Technical Support.

4.2 Cooking Procedures

Prior to beginning cooking operations check the following:

- Be sure that installation is complete & that the fryer has been prepared & properly cleaned as described in **Section 2**.
- Position the *Gas Valve Handle* located inside the cabinet (right side) in the **ON** position (*as indicated by label*).
- Be sure that proper ventilation to outside is provided for the operating area.
- Be certain that main gas supply line valve is **OPEN**, power cord is plugged into an appropriate outlet & main power supply for the outlet is **ON**.



4.2 Cooking Procedures

The following sections explain “*Best Practice*” procedures to use for cooking with the **GBF-80G Fryer**. If you purchased a multi-well unit (*GBF-80/80G or GBF-80/80/80G*), it may have certain *optional features* not available on the single fryer. They are explained in this manual where applicable, but please be aware that your particular multi-well equipment may or may not be equipped with any of these options.

The **GBF-80G** is a multi-purpose gas-fired fryer that efficiently cooks a variety of menu favorites from french fries to seafood. Food products have specific procedures for preparation & cooking and every business concern has their own specific standard procedures. Please be sure to follow all of your *standard practices & guidelines*, as they may *supercede some of the processes presented in this manual*.

4.2.1 Filling & Preparing Fryer for Cooking

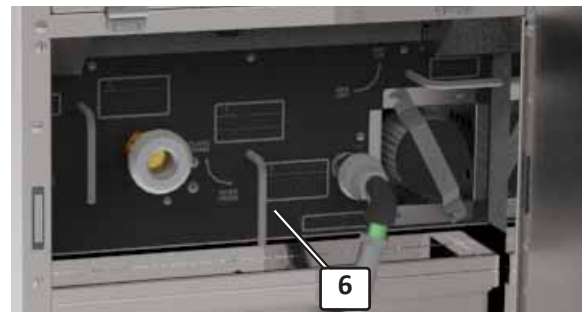

Remove vat screen & baskets from each unit, as needed, & set aside. Each unit of a multi-well appliance must be prepared using these same procedures.

1. Place **POWER** switch ① in **ON** position ... **POWER** light ② & controller ④ turn **ON**. Controller powers up as explained in *Section 4.1.10* and alarm sounds. At this time, **DO NOT** press the **[START]** key as prompted on the *upper display screen* ... press **[ALARM]** key ⑤ to silence alarm.
2. Ensure that the **HEAT** switch ③ remains **OFF** ... **DO NOT** place switch in **ON** position at this time.

NOTE:

After power-up, should the “**DRAIN OPEN**” alarm sound and error message displays on *upper screen* ④, check **drain valve handle**. Closing it fully & tightly should reset the error ... press the **[ALARM]** key to continue.

3. Even if there is no alarm, you should still open the cabinet door & verify that the **DRAIN** valve handle ⑥ is **CLOSED tightly (turned fully left to horizontal stop)**.

IMPORTANT! Burners will not ignite & heat unless drain is fully closed and valve interlock is engaged.

4. Fill vat with your preferred *fresh liquid frying shortening*. Fill **ONLY** to the **[ADD]** level mark to allow for oil to expand as it heats.

DO NOT use solid shortening in this fryer.

CAUTION Overfilling can result in overflow, excessive splatter and potentially result in personal injury and/or damage to equipment.

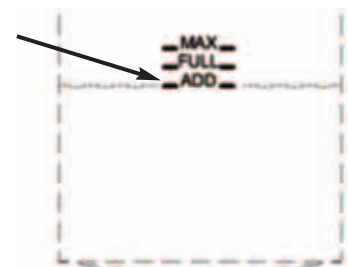

4.2.1 Filling & Preparing Fryer for Cooking - continued

OPTIONAL: Fill Vat Using Optional Bulk Fresh Oil Supply via Direct Fryer Connection

Option is ONLY available for a multi-well battery (2 or 3 units). Ensure that the *option* is properly installed & connected & the bulk system's pump has been properly wired into the control panel **ADD OIL** push-button switch.

A. Inside lower cabinet of unit to be filled, place the **PUMP OIL RETURN** valve ⑩ in **FILL VAT** position ... place the valves of all other units ⑪ in **CLOSE** position.

B. Press & hold the control panel **ADD OIL** push-button (only one panel of banked battery is equipped with the switch). Fresh oil from the bulk supply should soon begin flowing into the selected vat. You must continue pressing the button to run pump ... observe oil filling the vat. Release push-button to stop pump when level reaches the **[ADD]** mark in vat.

C. Return **PUMP OIL RETURN** valve ⑩, to the **CLOSE** position.

D. When oil in vat is at the proper level, continue to **step #7** below.

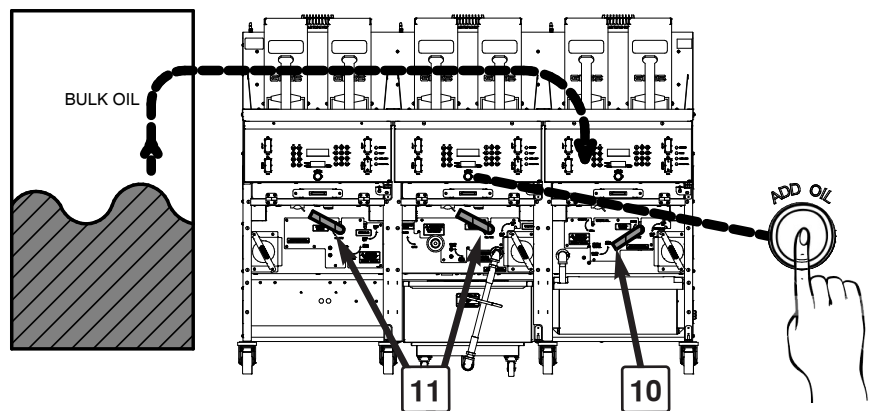

NOTE: Should oil not flow into vat, check the Bulk System pump, available quantity of fresh oil or possible clogged piping.

7. Set Controller for cooking:

Use keypads ⑦ to set the oil temperature *Section 4.1.3, Setting the Cooking Temperature.*

After setting, controller enters **PREHEAT** mode ... current cook settings are shown on the *upper controller display* ... real-time oil temperature is shown on *lower display*. **Fryer does not yet begin ignition sequence.**



8. Place the **HEAT** switch ③ in **ON** position & fryer heating is energized. The **HEAT** light ⑧ will turn **ON** ... ignition sequence begins ... *gas mixer/blower* starts & burners ignite to begin heating oil to the setpoint temperature. Combustion noise should be noticeable.

NOTE: If a proper flame is not detected at the burner within a few seconds, the ignition module & gas mixer/blower will shutdown, gas valve closes & the red control panel **FLAME FAIL** light ⑨ turns **ON**.

Return the **HEAT** switch ③ to **OFF**. Wait 2-3 minutes to allow gas to dissipate then return **HEAT** switch to **ON** & retry ignition.

If there are repeated ignition failures, see *Section 6, Troubleshooting* ... **Service call may be required.**

4.2.1 Filling & Preparing Fryer for Cooking - continued

CAUTION

Cooking oil is extremely HOT! Always wear thermal protection, such as gloves or oven mitts, when working near the open vat (stirring, loading/unloading, etc.).

Best Practice recommendation: Oil in the vat should be stirred occasionally while it is heating. This will help prevent the formation of “cool zones” & promote even heating throughout the total volume of oil. It is also helpful in avoiding false **HI-LIMIT** nuisance alarms, especially during the initial heating of a day, when shortening is cool & thickened.

9. When cooking oil temperature reaches the programmed setpoint, alarm sounds & display reads **“ALARM - STIR OIL”**. Press **[ALARM]** key to silence ... vigorously stir oil with the provided *stirring tool*. Controller goes into a ten (10) second delay ... during this time if stirring causes temperature to drop by a certain amount, **PREHEAT** mode continues until setpoint is reached again. Alarm sounds again when setpoint is required & display reads **“ALARM - SETPOINT REACHED”**. Press the **[ALARM]** key ... controller enters **READY** state & the *lower display* changes from actual oil temperature to show the controller temperature setpoint value.



10. After fully heating, confirm oil level ... it should now be at or near the **[FULL]** mark. If not, add the needed amount of oil & stir again. *If the HEAT light turns ON after adding additional oil, stir until it turns OFF again before cooking.*

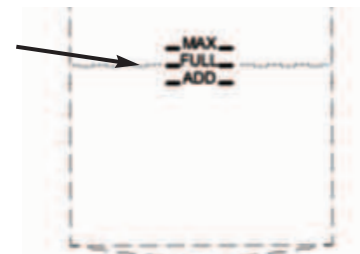

Cooking oil should now be evenly heated & ready for cooking ... continue to Section 4.2.2, Loading Product.

4.2.2 Loading Product for Cooking

1. Place *vat crumb screen(s)* ① into vat(s) ... handles should be positioned to the side. Screen rest on brackets affixed to the vat sides.
2. The standard GBF-80G fryer is equipped with a *manual basket hanger bar rack* on the back header of the cabinet ... hang empty baskets ② there.

Optional Auto-Basket Lifts: If the *Basket Lift option* is installed on your fryer, place the cooking baskets onto the *Basket Carrier Arms* ③.

If you wish to utilize the lift feature when cooking, set the control panel LIFT switch to the **ON** position. ***There is no switch if the option is not installed*** & some units of a banked battery can include lifts while others may not.

See Section 4.1.7.1 for details about manually operating basket lifts.

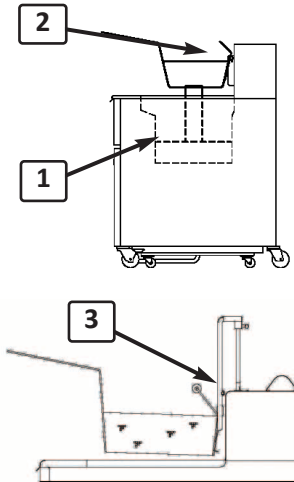

NOTE:

If you do not wish to use installed basket lifts, move both carrier arms to the **[UP]** position (see Section 4.1.7.1) & set the **LIFT** switch to **[OFF]** ... use carriers as the *manual basket hangers*.

WARNING

Oil level **MUST** be maintained between **[FULL]** & **[ADD]** levels while cooking. If level falls below **[ADD]**, the controller may issue a **LOW OIL LEVEL** error/alarm. As safeguard against possible oil fire, fryer heating is shutdown until the condition is corrected.

CAUTION

Use extreme caution when dropping product into **HOT** oil! There is potential for severe burn injury should hot oil contact unprotected skin, such as may occur with an unexpected splash.

Introducing foods containing excessive moisture (*ice crystals*) or attempting to cook a larger than recommended load size can lead to surge boiling, which could cause an overflow of **HOT** oil. Always observe how hot oil reacts when loading product, before continuing.

Best Practice recommendation: When loading the fryer, it is best to first place uncooked product into the *fry basket*, then place the loaded basket into the oil. This will help avoid possible burn hazards while handling food near hot cooking oil ... an unexpected splash or lack of operator attention could result in skin contact with hot oil & cause a serious injury.

Product may also be placed into oil after the basket has first been placed into the vat ... **this is NOT recommended**. Some operations may practice "*batch cooking*" without using baskets, then remove cooked product with a *scoop-style basket*. If doing so, always wear appropriate thermal protective gear (mitts or gloves) to avoid possible burns.

3. Load product to cook into basket as it rests on hanger bar, or the optional basket lift carrier.

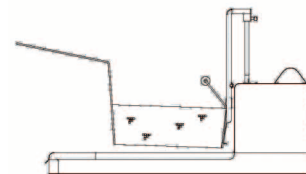

4.2.2 Loading Product for Cooking

- Set controller for proper cooking time of the product you are cooking ... either manually set time or choose the appropriate programmed *Menu Item preset*. See *Section 4.1.4, Manually Setting the Cook Time* or *Section 4.1.5.2, Selecting a Menu Item Preset for Cooking*. Setting are displayed on the upper screen ④.
If you are cooking different items at the same time, each basket may be set with a different time, or menu item preset ... the necessary cooking temperature must be the same for both items.

NOTE: If the user setting **“COOK ON MENU SELECT”** is set to **ON**, the timer cycle will begin as soon as a basket side is selected, without requiring any additional keystrokes.



4.2.3 Cooking Cycle Process

- Current controller cook settings selected (or entered) are be shown on the upper display screen ... item name & cook time for each side, oil temperature setting & the **READY** indication.

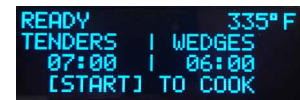

CAUTION

Always wear thermal protective gear, such as gloves or oven mitts, when handling hot baskets.

2A. Standard Fryer w/ Basket Hanger Rack:

Loaded basket on hanger rack ... press **[START]** key on keypad. You are prompted to select which side to start ... press keypad **[4] - [5] - [6]** to select ... **Immediately**, place the selected basket into vat, resting it on the support screen in the vat bottom ... programmed cooking time begins to count down shown on the *lower display screen*. Repeat as needed ...

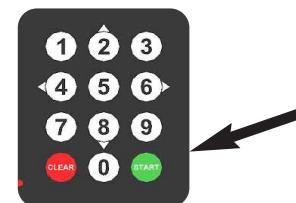

2B. Fryer w/ Optional Basket Lifts:

Loaded basket hanging on *lift carrier arm* ... press **[START]** key on keypad. You are prompted to select which side to start ... press keypad **[4] - [5] - [6]** to select. The selected basket lift automatically lowers basket into the vat ... programmed cooking time begins to count down shown on the *lower display*.

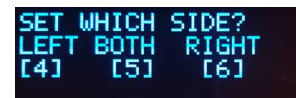

- The *upper display* shows message **“COOKING (LEFT) (RIGHT) or (BOTH)”**. *Lower display* shows the cook time remaining as countdown proceeds.



NOTE: If cooking different items in each basket, the second cook cycle is started same as described above, except the prompt for selecting side will show only one choice.



x 2

When timers are running different cycles, press the **[TIME]** key twice (2x) to swap *lower display* between timers. *Timer indicator* changes to show which side is displayed.

4.2.3 Cooking Cycle Process - continued

CAUTION

Always wear thermal protection, such as gloves or oven mitts, when handling hot baskets.

STIR ALARM:

Step #4 applies only if controller parameters below are set as shown, see [Section 4.1.8](#):

STIR ALARM ENABLE is **ON**
STIR OVERRIDE is set to **NORMAL** for the menu preset being used.

•• OR ••

STIR ALARM ENABLE is **OFF**
STIR OVERRIDE is set to **FORCE** for the menu preset being used.

If the settings are not as shown, **STIR ALARM** will *not* sound, however *Best Practice recommendation* is that product be stirred during the latter portion of the cooking cycle to help promote even cooking and to keep pieces separated while cooking.

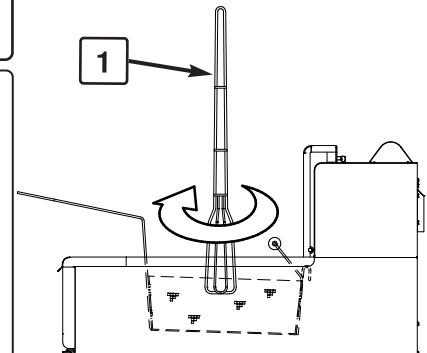

4. If settings are as shown above, **STIR ALARM** sounds after a preset amount of the programmed cook time has elapsed ... *upper display* reads "**ALARM - STIR (LEFT) (RIGHT) or (BOTH) SIDE**". Press [**ALARM**] key & use the provided tool ① to stir the cooking product. If basket lift is in use, be sure that basket does not become dislodged from the carrier arm while stirring.
5. When programmed cook time has elapsed, the alarm sounds & the controller *upper display* ② reads "**ALARM DONE COOKING - (LEFT) (RIGHT) or (BOTH)**".

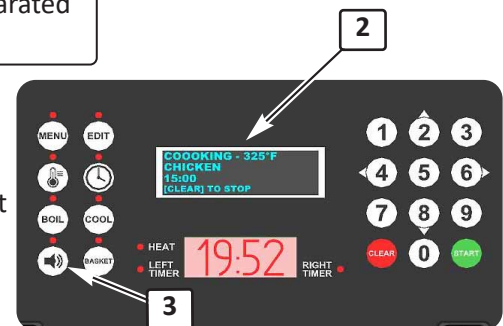

6A. Standard Fryer w/ Basket Hanger Rack:

Press [**ALARM**] key ③ to silence tone. Promptly remove proper basket from vat & hang onto the basket hanger rack ④.

6B. Fryer w/ Optional Basket Lifts:

The appropriate basket is automatically lifted from the oil. Press [**ALARM**] key ③ to silence tone. *If not using installed basket lifts, promptly remove basket manually & hang onto the raised basket carrier arm.*

7. Public health regulations & food safety guidelines typically specify that the internal temperature of cooked protein products indicate a prescribed level of doneness before being sold for consumption. In accordance with your standard operating procedures, the level of doneness should be checked when cooking is complete. It is best to check internal temperature with an instant-read, probe style, food thermometer. Should temp be lower than required, additional cooking time is needed.

The controller has a feature that can allow operator to easily add additional cooking time by pressing the [**0**] key + **mins. to add**. This can be done either after a cycle is complete or while it is still running. To use the feature, the *controller setting "0 KEY EXTRA TIME"* must be set to **ON**. See [Section 4.1.8, User Settings](#).

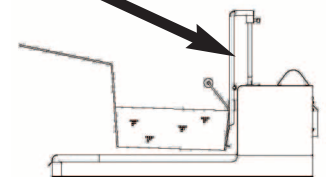
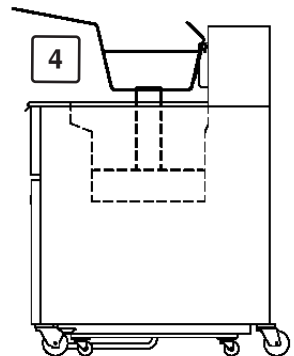

4.2.3 Cooking Cycle Process - continued

8. After doneness is verified, allow product to adequately drain, then dump into an appropriate dump station or food service pan. Always comply with health regulations pertaining to holding temperature & times for foods prior to sale.
9. To continue cooking, return to **Section 4.2.2, step #2**.

To shutdown unit, see **Section 4.06, Normal Shut-Down**.

4.3 Maintaining Oil Levels w/ Optional Oil Top-Off Systems

These options are ONLY available for multi-well banked batteries (2 or 3 units).

Cooking oil volume in vats will normally be depleted with every load cooked through *absorption, drag-out, splash & etc.* Continuing to cook with an oil level consistently below the **ADD** mark increases risk for vat fire. To help minimize the risk, the fryer's controller has a sensor circuit that can detect **LOW OIL LEVEL**, then issue an alarm & shutdown fryer heating. To avoid such possible interruptions & to continue safe operation, you **must routinely** monitor oil level & replenish vats with fresh oil, as needed to maintain level between **FULL** & **ADD**.

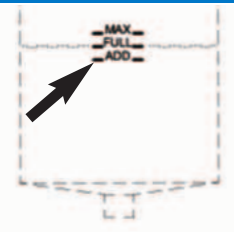

Multi-well GBF-80G banked battery fryers can be purchased with either of two different **optional oil top-off capabilities** ... **A. On-board top-off pump w/fresh oil tank system** or **B. Factory-installed plumbing for direct connection to a customer-provided bulk fresh oil supply system**.

A. Using Optional On-Board Top-Off System:



The on-board system pumps **fresh oil** from a **storage tank** located inside the right-hand cabinet. The tank has a capacity for approx. **70 lbs.** of liquid frying shortening & serves **all wells of the banked unit**. A suction pipe connected to **on-board top-off pump** reaches into tank at the front. Removable covers protect the stored oil from contamination.



The quantity of oil supply in this tank must be monitored & routinely maintained by operating personnel.

1. ***Clean tank before first use*** ... remove **tank cover front section** ①, rotate suction pipe ② up out of tank (it should move freely) ... slide tank (**with cover rear section**) from cabinet. Wash with hot water & a quality cleaner/degreaser ... rinse thoroughly & dry.
2. ***Fill tank with fresh oil*** .. replace the completely dry tank & rear cover section ... rotate the suction pipe ② back to the vertical position down into tank. From a jugs of your preferred liquid frying shortening, fill tank to about 1" or 2" below top lip. **Tank has capacity for 70 lbs.** ... typical purchased jugs contain 35 lbs. Replace **tank cover front section** ① ... close cabinet door.

4.3 Maintaining Oil Levels w/ Optional Oil Top-Off Systems

3. After every few loads cooked & after removing product from vat, check the oil level. If at, or below, the **ADD** mark, top-off vat with fresh oil as follows:

- Open cabinet door ... on unit to top-off, place the **PUMP OIL RETURN** valve (3) in the [FILL VAT] position. *Valves in all other units (4) must be in CLOSE position ... failure to have the valves closed can cause oil to be simultaneously pumped to an unintended vat & result in overfilling.*
- Press & hold the **ADD OIL** control panel push-button switch. Top-off pump will start to pump fresh oil from the on-board tank to the selected vat. **NOTE: There is only one ADD OIL push-button on a banked unit.**
- The top-off pump only runs while push-button is being pressed ...** continue holding switch & observe vat filling. Release switch when oil level reaches the **FULL** mark.
- To ensure that total volume of oil stays at proper cooking temperature, should the amber **HEAT** light turn **ON** while adding fresh oil, stir the vat until light turns **OFF** ... fryer should then be ready for the next load.
- To top-off a second vat in the banked battery, simply adjust the **PUMP OIL RETURN** valves in the lower cabinets, accordingly ... place valve of the second unit you want to top-off (3) in [FILL VAT] position & return valve of the unit just filled (5) to **CLOSE** position & verify that valves in any other unit (4) is closed. Perform steps to fill second vat same as described as above.

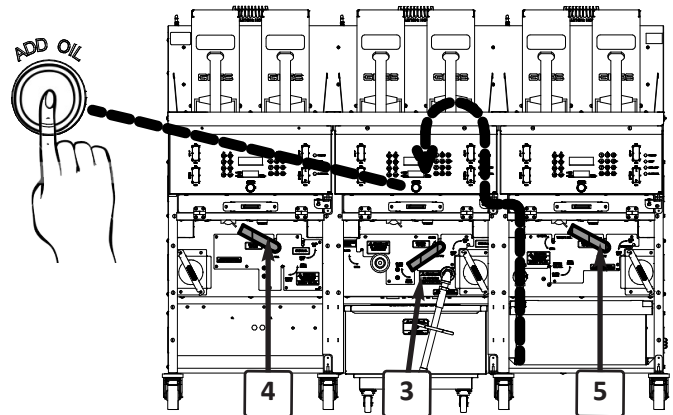
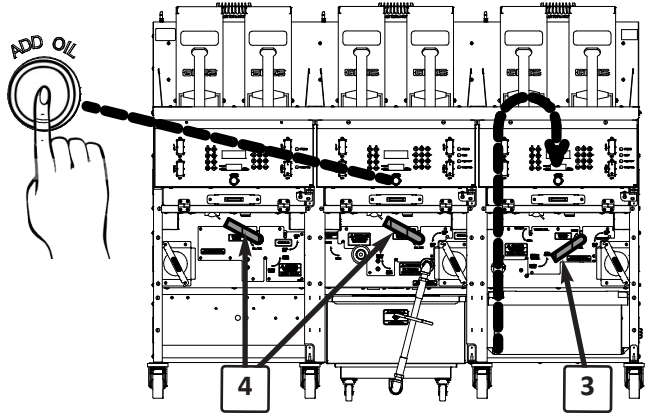

NOTE: Should the top-off pump stop while push-button is still being pressed, it is possible that excessive back-pressure has built-up in the system & the safety pressure interlock has shutdown pump to avoid damage. NO (or slow) oil flow may also be due to depletion of the on-board supply ... check that first! Then confirm that valves are set properly, check piping for blockages, etc.

MAINTAINING INTERNAL OIL STORAGE TANK:

Closely monitor fresh oil supply ... replenish regularly. *Avoid allowing supply to be completely depleted, unless cleaning is planned.*

- Remove the front section of tank cover & hang it over the lip of tank front. *There is no need to move the suction pipe out of the tank.*
- Using purchased jugs of fresh liquid frying shortening, fill tank to about 1" or 2" below the tank lip. Typical jugs contain approx. 35 lbs. & tank has capacity for 70 lbs.
- Replace the front cover section.
- Routinely remove & clean the internal tank, as described in **step #1** on the previous page.

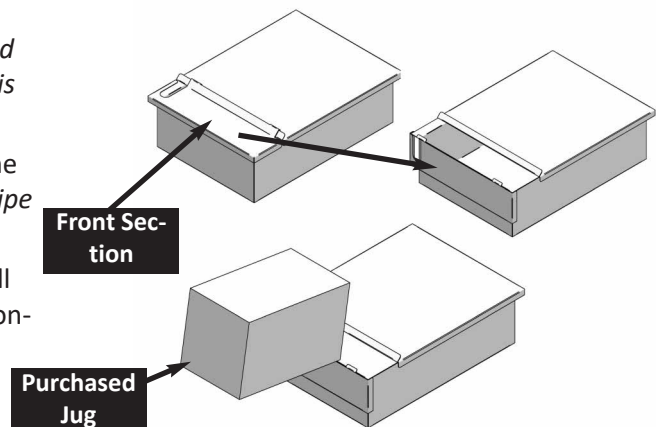

Continued on Next Page

4.3 Maintaining Oil Levels w/ Optional Oil Top-Off Systems

B. Using Optional Direct Connection to “Customer Provided” Bulk Fresh Oil Supply System:

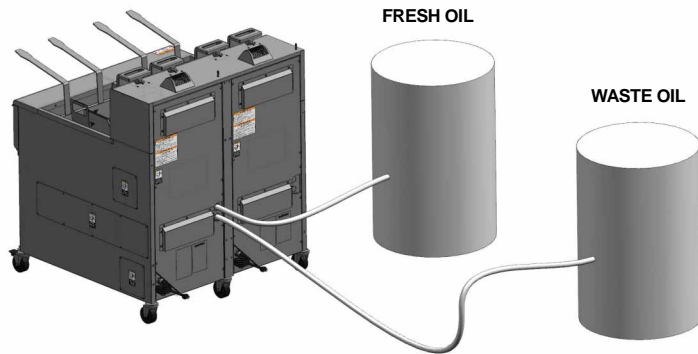

GBF-80G Multi-well fryer units can be purchased with optional factory-installed capability to be connected directly to a **customer-provided** bulk oil management system, which can either deliver fresh oil or handle waste oil disposal. Units can be ordered with either or both features.

Once bulk system is properly connected the fryer unit & its internal fresh oil pump is connected to the control panel **ADD OIL** switch, the vat top-off process is similar to use of the on-board tank version.

1. In lower cabinet of unit to top-off, place the **PUMP OIL RETURN** valve ③ in the **[FILL VAT]** position. *Valves in all other units ④ must be **CLOSED** ... failure to keep these valves closed can cause oil to be simultaneously pumped to an unintended vat & result in overfilling.*

2. Press & hold the **ADD OIL** control panel push-button switch. The internal pump of the bulk system will deliver fresh oil from the *bulk supply* to the selected vat. **NOTE: There is only one ADD OIL push-button on a banked unit.**

3. **The bulk pump only runs while push-button is being pressed** ... continue holding & observe vat filling. Release switch when oil level reaches the **FULL** mark.

4. To ensure that total volume of oil stays at proper cooking temperature, should the amber **HEAT** light turn **ON** while adding fresh oil, stir the vat until light turns **OFF** ... fryer should then be ready for the next load.

5. To top-off a second vat in the banked battery, simply adjust the **PUMP OIL RETURN** valves in the lower cabinets as previously described ... verify that valves in any unit(s) not intended to receive oil are closed. Perform steps to top-off second vat same as described as above.

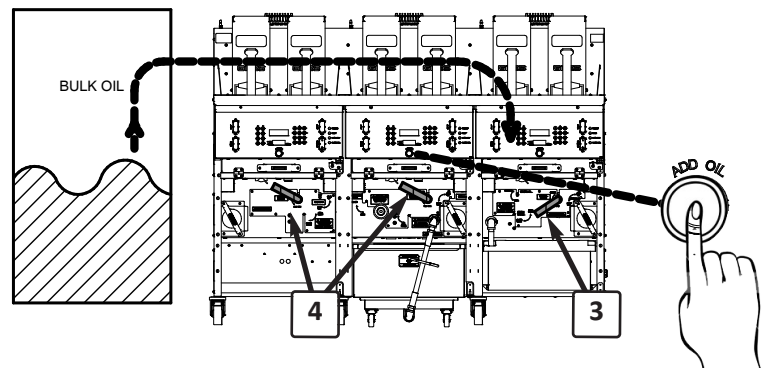

NOTE: Should oil flow from bulk system stop while push-button is still being pressed, it is possible that excessive back-pressure has built-up in the system & the safety pressure interlock has shutdown pump to avoid damage. NO (or slow) oil flow may also be due to a depletion of the bulk supply ... check that first! Then confirm that valves are set properly, check piping for clogs & refer to bulk system troubleshooting instructions.

4.4 Normal Fryer Shutdown

1. Place the Heat Switch ① in the center **[OFF]** position.
2. Place the Power Switch ② in the **[OFF]** position, Power Light ③ turns **OFF**.
3. Turn the Fryer Gas Valve Handle ④ to the **[GAS OFF]** position, turn left to stop at fully vertical.
4. If required to disconnect all supply power from the appliance, unplug power cord from receptacle, or turn **OFF** circuit breaker in the electrical panel supplying the unit.
5. If required, turn off main gas supply line valve.

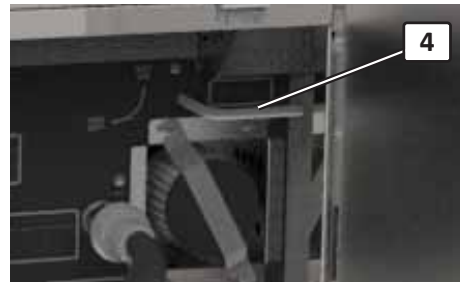

4.5 Emergency Fryer Shutdown

In case of emergency, remove power to the unit by turning off the facility circuit breaker and shut off main gas supply line.

5. Oil & Fryer Maintenance

This section explains procedures & activities for oil & fryer maintenance. Numerous benefits result from diligent & proper care of the oil and the fryer in general ... **fryer performance, improved oil life, improved food taste, better customer satisfaction, lower costs of operation & consistent food quality.**

5.1 Maintenance Supplies & Tools

Brushes & tools have been provided with your new equipment to aid you in maintaining it.

- 1 - **Heat-resistant Utility Brush** ... for scrubbing & cleaning inside vat surfaces during oil filtering & general cleaning activities.
- 2 - **Heat-resistant, Straight, Round-bristle Brush** ... useful for cleaning out vat drain valve & other hard-to-reach surfaces.
- 3 - **Heat-resistant, Long L-tip, Round-bristle Brush** ... useful for cleaning the underside of heat exchanger tubes & the vat surfaces beneath them.
- 4 - **Waste Oil Discharge Hose** ... connects to the fryer's filter pump system when removing waste cooking oil ... use to deliver waste to a suitable disposal container.
- 5 - **Crumb Shovel** ... after completion of an oil filtration cycle, use this handy metal scoop to remove crumbs & sediment from the surface of filter media in the *Filter Pan*.

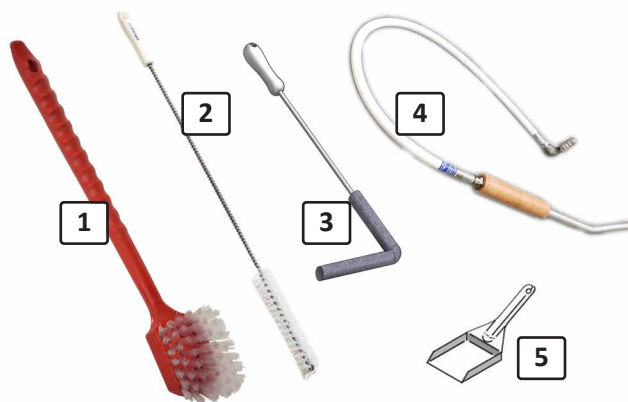

FILTER AID POWDER



FILTER PAPER



FRYER BOIL-OUT CLEANER

Giles also offers a line of fryer oil maintenance products, available through our dealers & distributors. Contact Giles Services at [800.554.4537](tel:800.554.4537) or email services@gfse.com for details & sources in your area.

- **FILTER AID POWDER (Item #72004)** ... Use when filtering cooking oil to remove soluble liquid impurities that contribute to *off- flavors & odors in oil* that can spoil your food quality ... a must for reconditioning oil & extending its useful life. **Case of (60) 4.8 oz portion packs.**
- **FILTER PAPER (various Item #'s)** ... 35 micron retention, disposable, paper filter media. Available in all the various sheet sizes to fit Giles fryers. Polishes used cooking oil by removing small crumb particles & fine cooking residue. Typically, if not torn or damaged during use, paper media can be cleaned off & used multiple times. **Case of 100 sheets.**
- **FRYER BOIL-OUT CLEANER (Item #72003)** ... Fill fry vat with water, add cleaner & dissolve, heat to 200°F for 30 mins. to breakdown & remove carbon deposits, fats & oils ... keeps your fryer looking & cooking like new. Can also be used without heat as an overnight soaking agent. **Case of (24) 6-oz packets.**

5.2 Filtering Cooking Oil

The following explains the fryer's built-in *Oil Filtration System* utilized to filter & recondition used cooking oil ... ***serves all the vats of a multi-well banked battery.*** The system pump draws used oil through a filter media in the *Filter Pan* ... removes small particle residue & impurities ... continuously recirculates oil back to the vat for several minutes to clean completely. Routinely performing the process can increase useful life of cooking oil by as much as 50%. *Giles suggests filtering oil after every 4th load cooked to keep fryer operation & food quality at an optimum level.*

The controller has a **FORCE FILTER** feature, which can be configured to force operators to filter oil according to a set routine ... see **Section 4.1.8, User Settings** & **Section 4.1.5.1, Editing a Menu Item Preset**. Fryer is forced into [**FILTER MODE**] after a set number of cook cycles (**FILTER COUNT**) have been completed. After the count is exceeded & the feature is **ON**, fryer will be **locked-out from further cooking operations** until oil is filtered. When feature is **OFF**, operator will only be **prompted** to filter oil after exceeding the *count* ... the controller prompt will occur after every subsequent load cooked until oil is filtered.

Factory-defaults: **FORCE FILTER** is [**ON**] ... **FILTER COUNT** is 4 ... **FISH FILTER** is [**OFF**].

FORCE FILTER SNOOZE setting is also available. When **ON**, **one (1) additional cook cycle** is allowed exceeding *filter count*. **Factory-default is [OFF]**. Controller settings may be changed in **User Settings, Section 4.1.8**.

CAUTION

Attempting to pump cold oil can clog the pump & result in damage. Oil should be moderately hot (200°F, 93°C) before attempting to pump.

Always wear thermal protection, such as gloves or oven mitts, while performing the filtering process ... parts inside the cabinet can be very HOT!

1. After cooking the number of loads defined by [**FILTER COUNT**], an alarm sounds.

2A. **FORCE FILTER - OFF:** Upper display ① reads "ALARM - FILTER OIL", press [**ALARM**] key ② to continue. Alert only, noting that oil needs filtering, **this alarm reminder will occur after each load cooked until oil is filtered.**

2B. **FORCE FILTER - ON:** Upper display ① reads "ALARM - MUST FILTER OIL", press [**ALARM**] key ②. Fryer is **locked-out from further cooking operation** until oil is filtered.



3. Place the **HEAT** switch ③ in [**OFF**] position ... **NOTE: POWER SWITCH MUST REMAIN ON DURING THE PROCESS**

4. Open cabinet & disconnect the *Filter Pan Hose* ④ at quick-coupler & remove *Filter Pan* ⑤ from the unit.

5. Remove *Pan Cover* ⑥ & verify that *filter media* (2 sheets) is in place properly & that any residue from a previous filtering has been removed ... ensure the media is in good condition.

6. Distribute approx. 5 oz. of *Filter Aid Powder* (1-pack of **Giles #72004 or other reputable product**) over filter media surface. **It is important that a suitable filter aid be used to remove soluble impurities & recondition oil.**

7. Replace *pan cover*, reposition the *filter pan* under the unit & reconnect the quick-coupling hose.

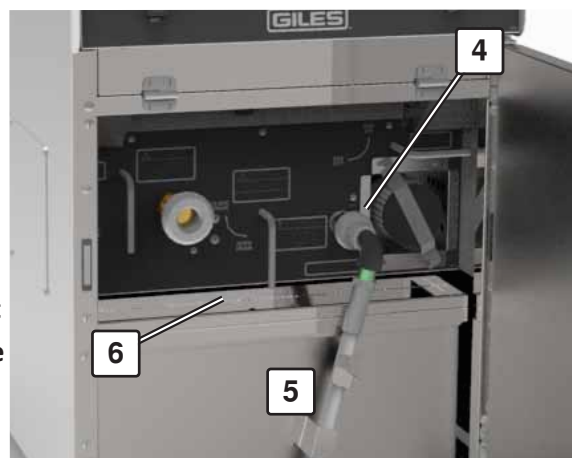

5.2 Filtering Cooking Oil - continued

⚠ DANGER During the next steps, cooking oil is drained from the vat, exposing the heat exchanger tubes. Failure to keep the HEAT switch in the [OFF] position prior to draining will cause burners to ignite & quickly heat the exposed tubes ... possible vat fire can result.

Even though Giles fryers are designed with safety interlocks which disable fryer heat anytime the DRAIN valve is opened, it is recommended that as a further safeguard against fire, always **KEEP** the HEAT switch **OFF** when draining oil ... **NEVER** consider the DRAIN valve as an ON/OFF switch for fryer heat.

8. If needed, remove *Baskets & Vat Crumb Screen* from the unit to be filtered & set aside ... verify that **HEAT** switch is **OFF**.

9A. **SINGLE FRYER UNIT:** Place the **OIL DIVERTER VALVE** (7) in the [OIL TO FRYER] position, vertical to stop.

9B. **MULTI-WELL FRYER UNIT:** On the unit to be filtered, place the **PUMP OIL RETURN** valve (9) in the [FILL VAT] position ... place this valve in all other units in the **CLOSE** position. Verify that the **DISCHARGE VALVE** (10) in the main unit cabinet (*w/filter pan*) is **OFF**

10. Slowly turn the **DRAIN** valve handle (8) to the **OPEN** position, indicated on cabinet label. Used oil should begin draining from the vat.

NOTE: If oil does not readily drain, use the provided *Drain Brush* (*straight, round bristle*) to break up crumbs & clear any valve blockage.

9. After the fryer vat has mostly emptied into filter pan, place the **PUMP** switch (11) in **ON** position. Oil should begin flowing back into the vat at the oil return port located on the rear vat wall.

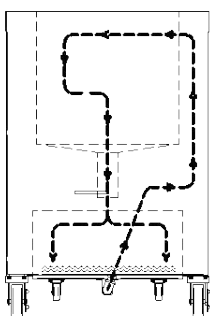
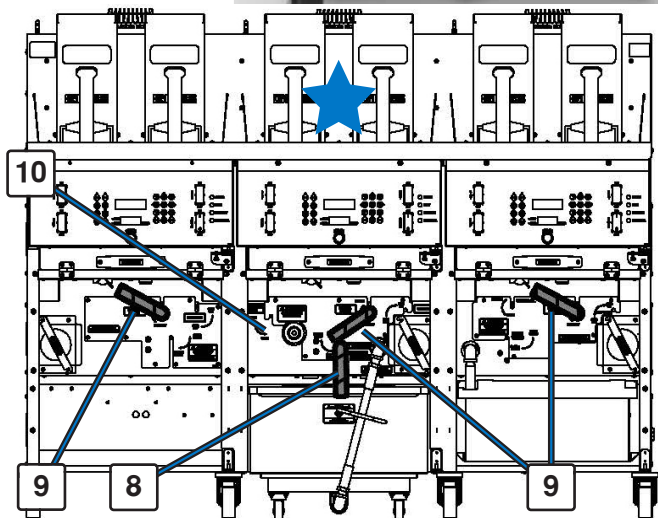
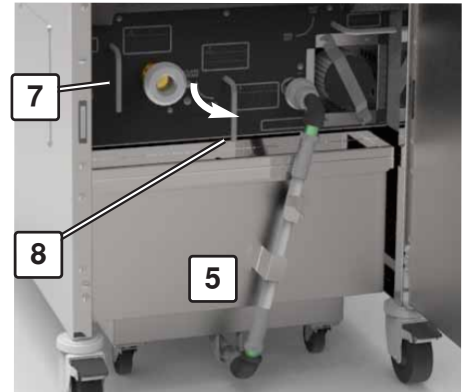

Leave DRAIN valve open & allow oil to continuously circulate through the system & back to the vat. To achieve sufficient filtration & reconditioning, allow the circulation for at least **5 minutes**.

During this time, use provided brushes to clean crumbs & cooking residue from the vat sides & heat exchanger surfaces, allowing it to be flushed into the *filter pan*. Use the *Utility Brush* for large surfaces ... use *L-tipped Round Brush* to clean between & under heat exchanger tubes.



Use the *Utility Brush* for large surfaces ... use *L-tipped Round Brush* to clean between & under heat exchanger tubes.

5.2 Filtering Cooking Oil - continued

10. After approx. 5 mins, return the **DRAIN** valve handle (8) to the **CLOSE** position, indicated on label. Allow the pump to continue running until the vat has been refilled with filtered oil.
11. When filtered oil has completely refilled the vat, place the **PUMP** switch (11) in **OFF** position to stop.

On a multi-well banked unit, return the **PUMP OIL RETURN** valve handle (9) to **OFF** position, indicated on label.

12. Check vat oil level ... if level is not between the **FULL** & **ADD** marks, add fresh oil to raise level. Replace vat crumb screen in the vat.
13. **NOTE: As safeguard against hot parts wear Thermal Protective Gear ...**
Disconnect quick-coupler *Filter Pan hose* (12), remove the *filter pan* & lift off the cover.

14. Use the provided *Crumb Scoop* to remove filter sediment from the surface of filter media & discard.

Unless there are obvious holes, tears or other damage, it is not necessary to replace the filter media after every filtering cycle ... filter pan must be cleaned & media refreshed, at least, weekly.

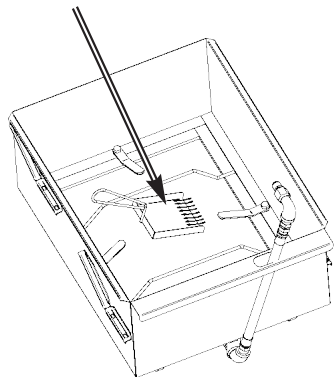

17. Replace *pan cover* & re-install *filter pan* in cabinet.
16. To continue cooking, See **Section 4.2, Cooking Procedure**.

To discontinue cooking, See **Section 4.4, Normal Shutdown**.

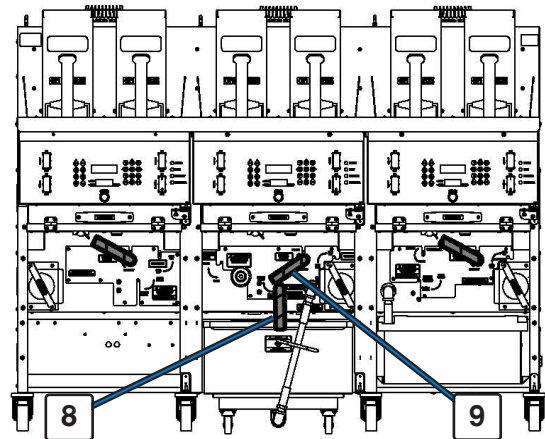
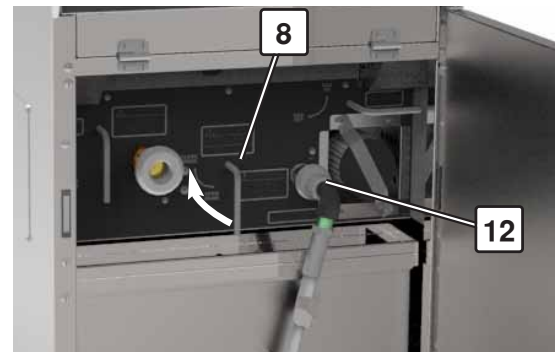

IMPORTANT!

When **FORCE FILTER** is ON, the controller will not exit **FILTER MODE** & return to normal operation unless oil temperature has decreased below, the [FILTER RESET] temperature in *controller user settings* ... *Default is 290°F*. Typically, oil will be cooled sufficiently during the filtering process to reset controller & unlock fryer.

To properly reset from **FILTER MODE**, the controller must be able to receive sensory inputs. For that to happen, the unit's **POWER** switch must remain **ON** throughout the filtering process. If switch is turned OFF, the controller will not receive the necessary inputs required to reset.

5.3 Removing & Disposing of Waste Oil

This section explains procedures for removing & disposing of waste cooking oil. To maintain food quality & fryer performance, oil should typically be changed every **7 to 10 days**, depending on filtering practices, types of food, quantities cooked, etc. Test kits are available for assessing oil condition & determining if it needs to be replaced ... they can be obtained from most any restaurant supply source. Oil must also be removed before cleaning & degreasing the fryer vat using the boil-out process.

GBF-80G Multi-Well fryers can be purchased, from the factory, with an **Optional Built-in Bulk Waste Oil** connection capability ... unit can be directly connected to a **customer-provided Bulk Waste Oil Handling System** with a remote tank to collect waste oil for pick-up. Please note that procedures will differ based on your equipment's particular configuration, see **Sub-Section 5.3.C**.



A. Removing Oil from Single Unit Fryer

CAUTION **DO NOT** attempt to pump oil when cold. Clogs can possibly occur & result in damage to filter pump seals. Oil should be heated to at least 200°F (93°C) before pumping.

1. If cold, preheat oil to around 200°F (93°C).
2. Be sure the **POWER** ① & **HEAT** ② switches are both **OFF**.
3. Ensure that the **filter pan** ③ is in place & the **filter pan hose** ④ is connected at the quick-coupler fitting.
4. Slowly turn the **DRAIN** valve handle ⑤ to the **OPEN** position, as indicated on label. Allow oil to drain completely from the vat.

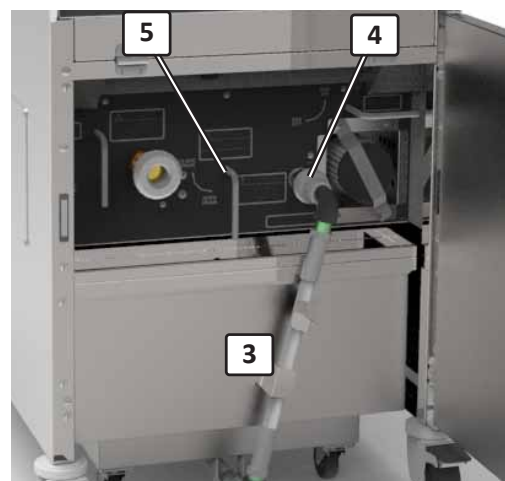

NOTE: If vat does not readily drain, or drains very slowly, use the provided *Drain Brush* (straight round bristle) to break up crumbs & clear the drain opening. **Be careful not to push brush down far enough to puncture the filter media ... that could possibly allow the pump to ingest debris & be damaged.**

5.3 Removing & Disposing of Waste Oil - continued

A. Removing Oil from Single Unit Fryer - continued

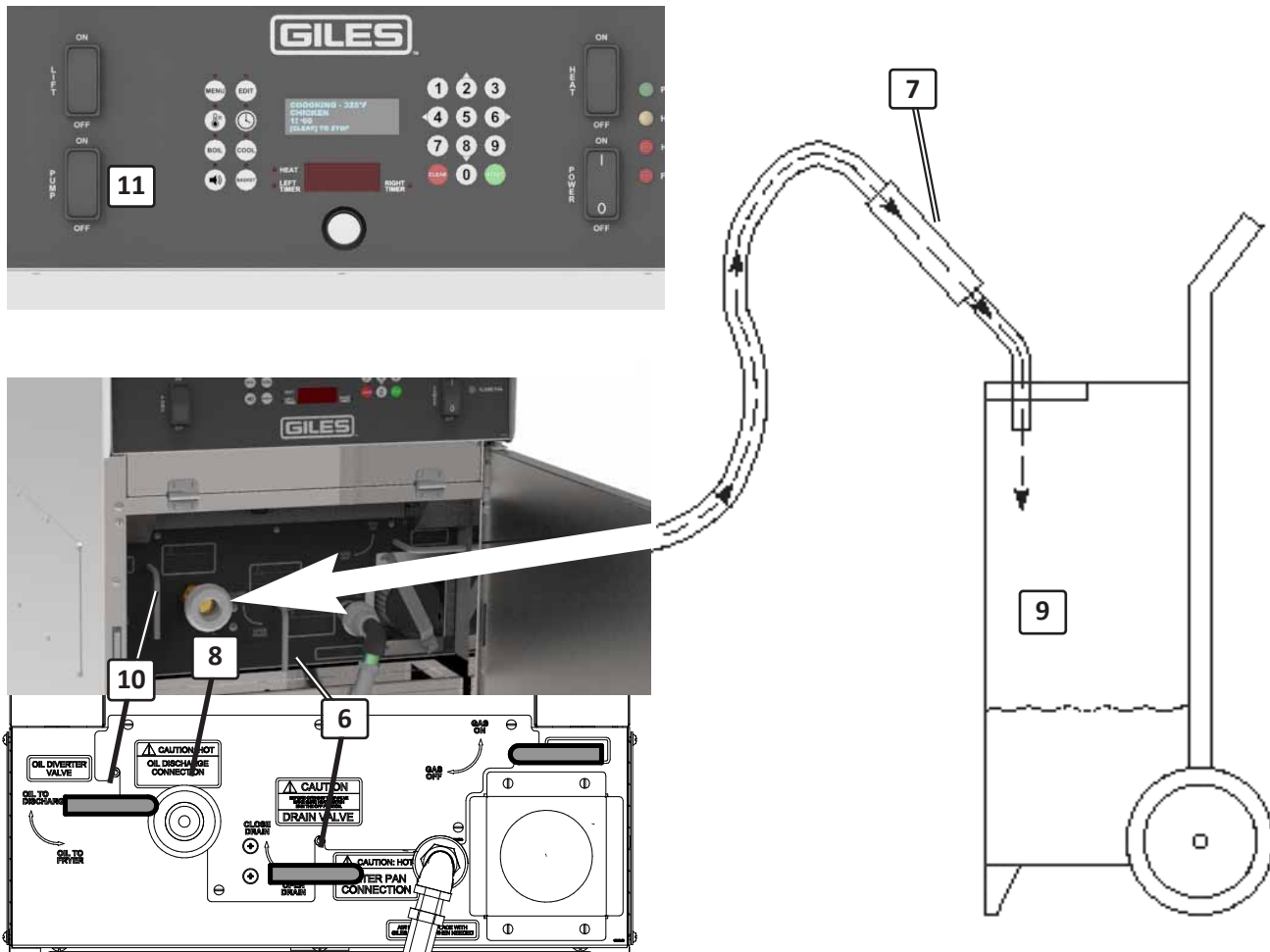

5. After the vat has completely drained, return the **DRAIN** valve handle (6) to **CLOSE**, as indicated on cabinet label.
6. Connect the provided **Waste Oil Discharge Hose** (7) to the quick-coupler fitting (8).
7. Place the *discharge wand* end into a suitable heat-resistant waste oil disposal container (9) (*Giles Oil Caddy is depicted*) ... **NOT PROVIDED**.
8. Place the **OIL DIVERTER VALVE** (10) in [**OIL TO DISCHARGE**] position (*left to stop at fully horizontal*).

9. **CAUTION** Wear thermal protective gear if you will be holding the *Discharge Hose Wand* ... parts of it will become very hot while pumping oil.

Set the **PUMP** switch (11) to **ON**. Pump starts & waste oil is pumped from *filter pan* into the disposal container. **IMPORTANT!** Always attend this process to avoid the possibility of serious oil spillage while pump is running.

5.3 Removing & Disposing of Waste Oil - continued

10. After all waste oil has been pumped from the *filter pan* into container, return the **PUMP** switch to **OFF** position.
11. Return **POWER** switch to **OFF**.
12. Return the **OIL DIVERTER VALVE** handle ⑩ to the [**OIL TO FRYER**] position (*right to stop at fully vertical*).
13. **Wear thermal protective gear**, remove the *Discharge Hose* from the quick-coupler fitting & drain any oil remaining in it into the *disposal container*.
14. Thoroughly clean the *filter pan* & *filter pan cover* ... dry parts completely. Refresh the filter media pan. Refer to **Section 5.5, Cleaning Filter Pan & Refreshing Filter Media**.
15. **IMPORTANT!** Before refilling fryer vat with fresh oil, it is recommended that a **Boil-Out cleaning** procedure be performed each time waste cooking oil is removed. This will remove carbon deposits on vat & heat exchanger surfaces & keep your equipment looking new. Over time, such deposits will negatively impact cooking performance & food quality.
16. See **Section 5.4, Boil-Out Procedure** for details. If boil out cleaning must be delayed, at the minimum, remove excessive oil residue from vat with absorbent wipes prior to refilling with fresh oil.

To shut down unit, see **Section 4.5, Normal Shut-Down**.

B. Removing Oil from Multi-Well Banked Unit Fryers (using Standard Discharge Hose)

1. Ensure that *filter pan* ③ is in place & *filter pan hose* ④ is properly connected at the quick-coupler fitting in the main unit.
2. On the unit to be drained, ★ slowly turn the **DRAIN** valve handle ⑤ to the **OPEN** position, as indicated on cabinet label. Allow oil to drain completely from the vat.
3. Verify that **PUMP OIL RETURN** valves ⑥ of all fryer units are in the **CLOSE** position.
4. As described in **Sub-Section 5.3.A**, connect the *Waste Oil Discharge Hose* at the quick-coupler fitting ⑧ in the main unit (*with the filter pan*).
5. Turn the **DISCHARGE VALVE** ⑩ to the **OPEN** position (*located beside discharge hose connector*).
6. To complete the oil removal process, generally follow the steps as described beginning with **Step #9** of **Sub-Section 5.3.A** on the previous page. When oil has been removed from the selected vat, return **DISCHARGE VALVE** ⑩ to **CLOSE**.

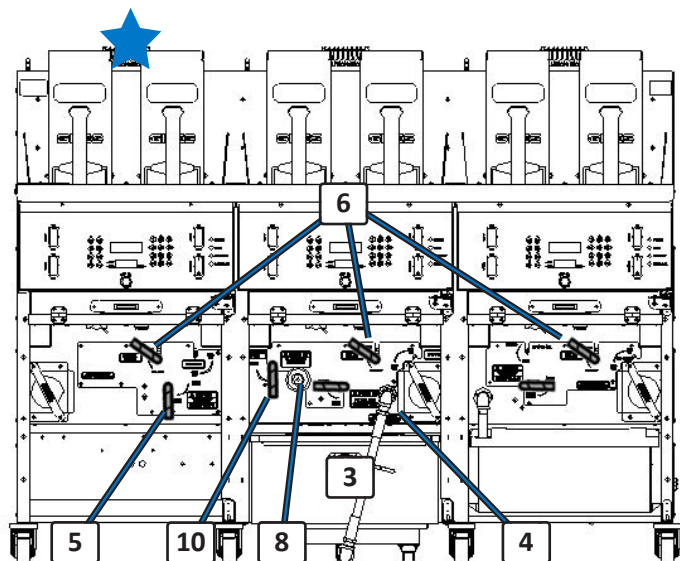

5.4 Boil-Out Procedure (Cleaning the Fry Vat)

C. Removing Oil from Multi-Well Banked Unit Fryers (Optional Bulk Waste Oil)

GBF-80G Multi-Well Banked fryers can be purchased with an **Optional Bulk Waste Oil System** connection capability. Unit is piped directly to a **customer-provided Bulk Waste Oil Handling System**, having a remote tank to collect waste oil for pick-up & disposal. Units equipped with this option still have the alternative of removing waste oil using the manual **Discharge Hose**. The following steps describe use of a **bulk waste system**.

1. Ensure that the **filter pan** (3) is in place & **filter pan hose** (4) is properly connected at the quick-coupler fitting in the main unit. Verify that **PUMP OIL RETURN** valves (6) of all units are in the **CLOSE** position.
2. *On the unit to be drained*, slowly turn **DRAIN** valve handle (5) to the **OPEN** position, as indicated on cabinet label. Allow oil to drain **completely** from the vat.
3. Turn the **WASTE OIL** valve handle (11) to the **OPEN** position (*located in cabinet to right of main unit*). Ensure that the **DISCHARGE VALVE** handle (10), in main filter pan unit is positioned to **CLOSE**.

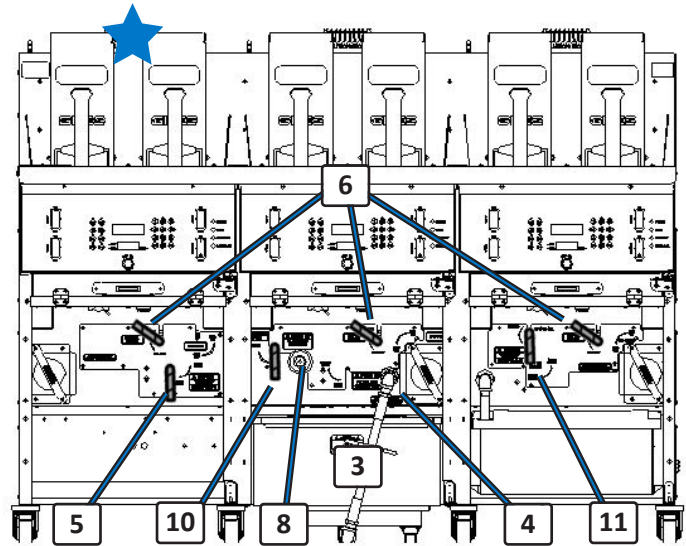

IMPORTANT! When choosing to use the **manual Discharge Hose** rather than the installed **Bulk Waste Oil** system option, be sure to keep the **WASTE OIL** valve (11) positioned to **CLOSE**.

5. Set the **PUMP** switch (12) on main unit panel to **ON**. The fryer's filter system pumps waste oil from filter pan to the bulk waste oil collection tank.



Should **excessive back-pressure** build up, an internal pressure switch will automatically shutdown pump to prevent damage ... shutdown can indicate that the bulk tank may be full, valves are set improperly, plumbing is clogged, etc. Consult the bulk system operational documentation for recommended troubleshooting procedures.

6. Attend the pumping process & return **PUMP** switch to **OFF** when the pump sound changes & it seems to be running empty. Return **WASTE OIL** valve (11) to **OFF**.
7. To complete the oil removal process, generally follow the steps as described beginning with **Step #11** of **Sub-Section 5.3.A** on the previous page.

NOTE: If the bulk collection tank fills before completely removing waste oil, use the manual **Waste Oil Discharge Hose** to finish the process ... see **Sub-Section 5.3.B**.

5.4 Boil-Out Procedure (Cleaning the Fry Vat) - continued

This section explains cleaning fry vat(s) using a **Boil-Out Procedure**. It must be performed before cooking the first time on the new equipment & should be performed any time used cooking oil is removed, before being replaced with fresh. **IMPORTANT!** For proper cooking performance, fryer operation & to maintain consistently satisfactory food quality, a boil-out procedure should be performed every 10 to 14 days, at a minimum.

CAUTION

- The process does not require a rolling boil, however, **DO NOT** leave the fryer unattended during the procedure. You must carefully monitor the process & be attentive for any occurrence of accidental overflow, which can result in serious equipment damage.
- The boil-out solution & parts of the equipment will be **HOT** at end of the process ... when draining spent solution & cleaning, always wear protective gear (gloves or mitts, face-shield, latex apron, etc.).

1. Remove cooking oil from the unit to be cleaned, see **Section 5.3, Removing & Disposing of Waste Oil**. Wipe out any heavy oil residue with absorbent wipes.

2. On the vat to be cleaned, be sure that the **DRAIN** valve ① is positioned to **CLOSE** (as indicated on cabinet label) & verify that **POWER** & **HEAT** switches are **OFF** & the unit's **GAS VALVE** is positioned to **ON**.

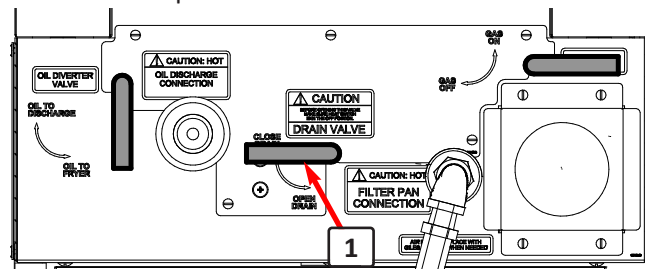

3. Fill vat with fresh clean, ambient temp, water to the **FULL** level.

Giles Fryer Boil-Out (Item #72003) is recommended for cleaning & degreasing the fry vat. It dissolves & removes carbon deposits, helps preserve oil longevity & keeps foods tasting great ... it is a non-caustic cleaner & multipurpose degreaser that can keep your fryer looking brand new. **Giles Boil-Out** is supplied in convenient pre-measured packets ... typical fryers require (2) packs per cleaning.

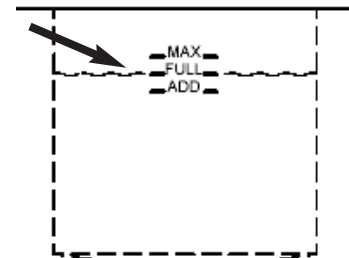

4. Follow the use directions of the product being used ... add the prescribed amount of cleaner product to the water & stir to mix.

If using a cleaner other than **Giles Boil-Out**, closely follow the manufacturer's usage instructions. Some commercially available cleaners may contain chemicals, which require special precautions. If used improperly, personal injury and/or damage to the equipment could occur.

CAUTION

5. Place **POWER** switch ③ to **ON**. After controller powers-up, press **[ALARM]** key ⑥, then press **[START]** key to enter **PREHEAT**.

Place **HEAT** switch ④ to **ON** ... the burners should ignite, momentarily.



5.4 Boil-Out Procedure (Cleaning the Fry Vat)

- Press the **[BOIL]** key (5) ... controller enters **BOIL OUT MODE**, temperature setpoint changes to **200°F** & boil-out cycle time begins to countdown from **30 minutes**. Cleaning solution will heat to set temp.
- Default **Boil Out Temperature & Time** are factory-set at **200°F & 30 mins**. If different temperature or time is required, the settings can be edited in **User Settings, Section 4.1.8**. **BOIL TEMP** is variable between **185° - 208°F**. **BOIL OUT TIME** is variable between **1 - 45 minutes**.



- At the completion of the boil-out time, an alarm sounds & the upper controller display shows the message **"DONE COOKING"**.
- Press the **[ALARM]** key (6).
- Return **POWER** switch (3) & **HEAT** switch (4) to **OFF**.
- Disconnect **filter pan hose** & remove the **filter pan** from fryer. **DO NOT drain boil-out solution into the filter pan!** Chemicals may be corrosive & can cause damage to the pan & pump. **Such damages may not be covered by the factory warranty.**



To exit BOIL OUT MODE before completion, press [CLEAR] + [4]

- Position a suitable **heat-resistant container** (6) beneath the fryer drain. **For multi-well units, all vats drain under the main filter pan unit.**

**Giles offers a boil out caddy (BOC) designed for this process which can be purchased separately. Otherwise, container used for this step must be heat resistant up to 300°F (148°C). Common plastic containers are not acceptable ... they can melt or break. A leak-proof metal container is ideal. Failure to comply with this caution may result in personal injury.*

- Slowly turn the **DRAIN** valve handle (7) on the **boil-out unit** to **OPEN**, as indicated by cabinet label. Drain spent boil-out solution into catch container. Carefully monitor draining & empty container as needed. As solution drains, use the provided brushes to scrub & clean the heat exchanger tubes & vat surfaces to help remove the residue.
- Rinse and flush the vat thoroughly with hot tap water. **Empty catch container as often as needed so as to prevent any overflow.**

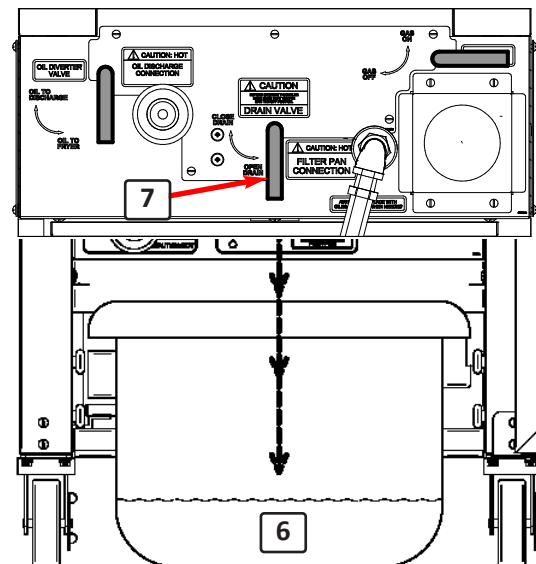

- Wipe vat dry with clean dry, sanitized, towels. Ensure surfaces are completely dry before adding fresh cooking oil.
- Slowly turn the Drain Valve Handle (7) to the **[CLOSE]** position (turn left to stop at fully horizontal).
- Clean the **filter pan** & replace **filter media** ... refer to **Section 5.5, Cleaning the Filter Pan & Refreshing Filter Media**.

5.4 Boil-Out Procedure (Cleaning the Fry Vat) - continued

16. Replace *filter pan cover* on *filter pan* & position pan underneath unit ... connect the *filter pan hose* at the *quick-coupler fitting* ⑧.
18. To begin cooking on the unit, refer to **Section 5.2, Cooking Procedures**.

IMPORTANT!

- *Be certain that vat surfaces are completely rinsed & dry before adding fresh cooking oil. Give particular attention to the drain area ... residual water may accumulate in the space above the ball valve. Water in the oil will cause boiling & foaming when heated ... oil overflow can result.*
- *As a safeguard, at the conclusion of the Boil-Out Procedure, the controller automatically resets the cooking temperature setpoint to 50°F. Before you can continue to cook in this unit, a proper cooking temperature must be re-entered into the controller, after adding fresh cooking oil.*

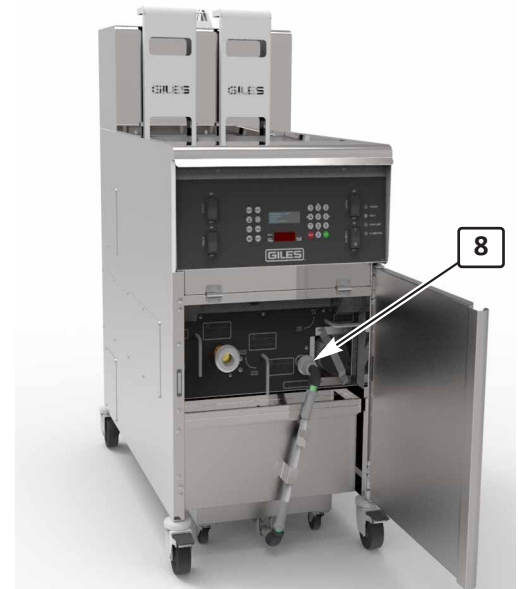

5.5 Cleaning the Filter Pan & Replacing Filter Media

This section describes the process for cleaning the *Filter Pan* & replacing *filter media*. The process should be performed immediately after each **Boil-Out Procedure (Section 5.4.)** and as part of a **daily cleaning routine**, regardless of whether the boil-out was performed.

Wear thermal hand protection as parts can be HOT.

1. Follow the normal shutdown procedure, *see Section 4.5.*
2. Disconnect & remove the *Filter Pan* ① along with the *Pan Cover* ② from the fryer cabinet.
3. Remove the *cover* ② ... clean with warm water & mild degreasing solution such as **Simple Green Foaming Crystal Cleaner®**. Rinse, dry thoroughly & set aside.
4. Remove the *Crumb Catcher Screen* ③, clean & dry thoroughly.
5. Using the provided metal Crumb Scoop, remove most of the accumulated filter residue from the surface of the filter media ⑤.
6. Turn the (4) four *locking levers* ⑥ to disengage the *Hold-Down Frame* ④ from the pan. Remove the frame ... clean with degreasing cleaner, dry thoroughly & set aside.
7. Taking care not to drop excessive filter residue into the pan, grasp & roll up the soiled sheets of *filter media* ⑤ discard properly. Lift out the ribbed *Support Grate* ⑦. Clean & thoroughly dry ... set aside.
8. After all of the parts have been removed, thoroughly clean *Filter Pan* ⑧ with a mild degreaser & warm water. Thoroughly rinse pan & use water spray to flush out the hoses. Dry the pan completely, then be sure to drain all water from the hoses.
9. In reverse order, reassemble the filter pan complete ... replace filter media with two (2) new sheets of *filter paper media*.
10. Place *pan cover* onto & position assembly in fryer cabinet ... reconnect *filter pan hose*. Be sure the hose is securely connected in the quick-couple fitting.

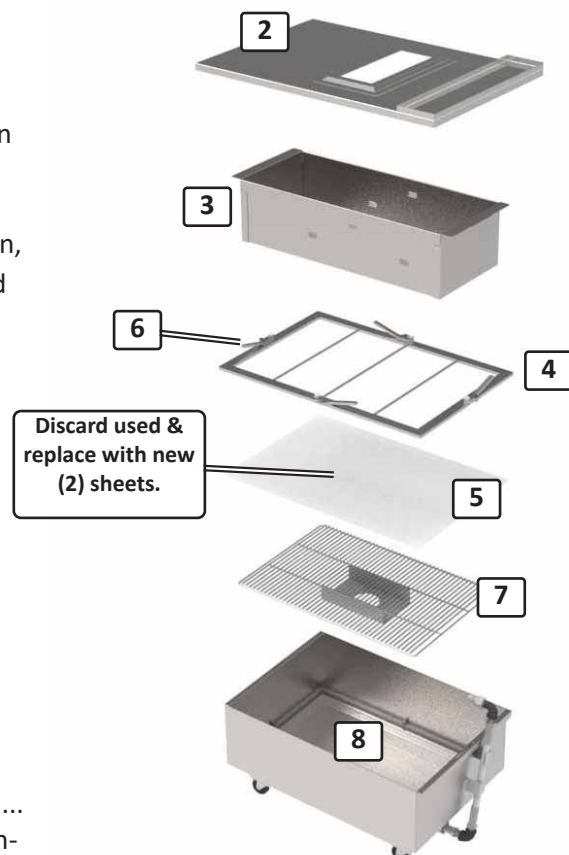
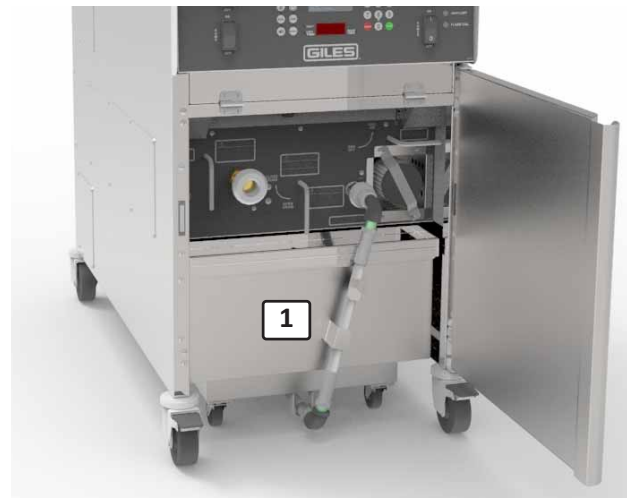

5.6 Air Filter Maintenance

1. As a general rule, you should plan to remove & clean the combustion air filter on the same frequency as a scheduled fryer boil-out, or some other activity, to ensure that it is being routinely cleaned.
2. Clean this filter with a water & soap (*Dawn*) solution, or a foaming degreaser such as ***Simple Green Foaming Crystal Cleaner***[®], which Giles recommends for general fryer cleaning.
3. Filter is slip fit onto the intake tube & can be removed without tools. Thoroughly wet both sides of the filter with clean water. Liberally spray cleaner onto the dirty side & allow it to soak for a few minutes ... ***Do Not Allow To Dry!***
4. Rinse filter with low-pressure cool water ... spraying from the clean inside side out. Filter should not be brushed. Rinse until all traces of cleaner are removed. Repeat process if needed.
5. Allow filter to air dry naturally before reinstalling. **NEVER OPERATE WITH A WET FILTER OR WITHOUT FILTER INSTALLED.**

This filter will typically not require replacement unless it becomes significantly damaged in some way ... tears, holes, will not fit tightly, etc.



6. Troubleshooting

This section describes some general troubleshooting procedures for the **GBF-80G Gas Fryer**. Refer to the wiring diagram provided with the unit, as needed. Typically, in-depth troubleshooting must be performed by qualified kitchen equipment service personnel. Owner/operators should only attempt to correct issues that are procedural or operational in nature & should **NOT** attempt technical electrical or mechanical repairs.



Inspection, testing and repair of electrical components should ONLY be performed by factory-authorized service agents.

6.1 Temperature Control System

Problem	Probable Cause	Repair Procedure
FRYER WILL NOT TURN ON: No power light	A. Not connected to power source.	Plug power cord into wall receptacle.
	B. Blown fuse or tripped circuit breaker.	Check fuse or breaker.
	C. Faulty fuse holder.	Inspect & replace as needed.
	D. Faulty POWER switch.	Test & replace as needed.
	E. Improper supply voltage.	Have incoming line voltage verified.
FRYER WILL NOT HEAT: POWER light ON . HEAT light OFF ... No alarm sounding	A. HEAT switch not positioned to ON .	Place switch to ON .
BURNERS NOT ON ... FRYER NOT HEATING: POWER light ON HEAT switch ON HEAT light OFF Alarm may be sounding ...	A. Actual oil temperature is higher than controller setpoint.	Check setting & oil temp, correct if needed ... if satisfactory begin cooking.
	B. “ DRAIN OPEN ” message ... alarm sounding	Close valve fully to reset alarm
	C. Faulty controller.	Test ... replace controller if needed.
	D. Temperature sensor faulty, Er13 displayed	Check wiring, replace sensor
	E. Faulty HEAT switch	Test ... replace as needed
	F. Draft blower vacuum switch out of adjustment	Adjust vacuum switch ... see Owner’s Manual
	G. Power-up procedure not completed	Press [START] key to begin PREHEAT

6.1 Temperature Control System - continued

Problem	Probable Cause	Repair Procedure
FRYER WILL NOT HEAT (IGNITE): POWER light ON. HEAT light ON FLAME FAIL light ON	A. Main gas supply line valve is CLOSED .	Check & open gas valve.
	B. Fryer gas valve is CLOSED .	Position gas valve handle inside cabinet to OPEN .
	C. Flame sensor faulty, dirty or misaligned.	Inspect ... clean, adjust or replace sensor.
	D. Improper incoming gas pressure.	Consult gas utility supplier ... correct pressure
	E. Faulty solenoid valve.	Inspect ... replace valve, if needed
	F. Faulty gas mixer / blower.	Inspect/repair/replace Mixer or Blower.
	G. Faulty Ignition system	Inspect/repair as needed.
	H. Faulty transformer.	Check/replace as needed
	I. Dirty gas burners.	Clean burners.
BURNER NOT ON ... FRYER NOT HEATING: POWER light ON. HEAT light OFF. Alarm sounding / error message displayed.	A. Drain valve open.	Close valve completely.
	B. Loose wiring.	Check & repair wiring.
	C. Low oil level	Add oil to FULL level.
	D. Heat exchanger has exceeded max temp	Allow unit to cool ... error will clear automatically
	E. Improper filtering procedure. FORCE FILTER not reset.	Turn OFF power, allow fryer to cool & restart.

6.1 Temperature Control System - continued

Problem	Probable Cause	Repair Procedure
BURNERS OFF ... FRYER WILL NOT HEAT: POWER light ON . HI-LIMIT light ON	A. Power surge has tripped safety thermostat	Turn power OFF for 5 seconds to reset.
	B. Plug loose in wall receptacle.	Check & insert plug firmly.
	C. Low oil level	Add oil to FULL level.
	D. Faulty High-Limit board	Replace board.
	F. Faulty or mis-positioned high-limit probe.	Replace Probe; check & reposition if needed..
	G. Line noise or voltage spikes.	Install line filter.
FRYER HEATS SLOW: Slow recovery HEAT light stays ON .	A. Improper cooking procedure.	Refer to Owner's Manual for proper procedures.
	B. Burner system malfunction	Inspect system.
	C. Incorrect gas pressure.	See <u>Section 2.7.1, Typical Gas Line Connections</u> . Consult gas utility provider.
FRYER HEATS SLOW: HEAT light OFF & ON CONTINUOUSLY . Short cycling	A. Low voltage.	Check incoming power supply & connections.
	B. Variable temp sensor is touching, or too close to heat exchanger.	Correct location.
	C. Faulty controller.	Test ... replace controller, as needed
	D. Loose wiring.	Inspect wiring & repair.
OIL TEMPERATURE ERRATIC:	A. Faulty variable temp sensor.	Replace faulty sensor
	B. Burner system issue.	Inspect system ... repair.
	C. Faulty controller.	Test ... replace controller.
	D. Loose wiring.	Inspect wiring & repair.

6.1 Temperature Control System - continued

Problem	Probable Cause	Repair Procedure
OIL SMOKING:	A. Cooking oil is old	Change cooking oil.
	B. Cooking temp too high	Check settings.
	C. Low oil level	Maintain oil at FULL level
	D. Contaminated oil	Change cooking oil.

6.2 Oil Filtration System

Problem	Probable Cause	Repair Procedure
OIL NOT PUMPING BACK TO FRY VAT:	A. PUMP switch not positioned to ON	Place switch in proper position.
	B. Air leak in system.	Check hoses & filter pan connections.
	C. Faulty pump motor.	Inspect ... replace if needed.
	D. Pump head clogged or bound.	Remove head cover ... clean pump as needed.
	E. Valves (DIVERTER or PUMP OIL RETURN) not set properly.	Check ... place valve handle in proper position.
	F. Oil has congealed inside pump head.	Run clean hot oil through system.
	G. Oil too cool to pump efficiently	Remove filter pan & manually remove cool oil.
	H. Filter pan assembled incorrectly.	Assembly filter pan correctly ... see Section 5.5 .
	I. Pump has been damaged by pumping boil-out solution.	Disassemble pump head ... clean & re-oil.
	J. Filter pan contains an excessive amount of crumbs & residue.	Manually remove oil, clean pan & refresh filter media.

6.3 Basket Lift System (Optional)

Problem	Probable Cause	Repair Procedure
BASKET LIFT WILL NOT OPERATE:	A. POWER not ON .	Position POWER switch to ON
	B. Control panel LIFT switch is in OFF position	Position LIFT switch to ON
	C. Controller keypad issue.	Perform key function diagnostics.
	D. Cook cycle is running.	Cancel running cycle.
	E. Elevator micro-switches out of adjustment.	Adjust switches.
	F. Oil temp has not yet reached setpoint ... controller still in PRE-HEAT .	Wait until oil heats to setpoint & fryer enters READY state.
	G. Basket lift motor is faulty.	Inspect ... replace if needed.
	H. Controller is faulty.	Test ... replace if needed.
	I. Wiring issues	Inspect ... repair as needed

7. Parts List

This section lists various parts that, typically, can be field replaced on *GBF-80G Gas Fryers*. It is provided as a resource for trained technicians who are servicing or repairing the equipment. In-depth equipment repair should **ONLY** be attempted by qualified kitchen equipment service personnel.

7.1 Part Ordering & Service Information

Giles is an equipment manufacturer & does not sell parts direct to users. Service parts are available through our authorized service agents, parts distributors & equipment dealers. If you need assistance with sourcing parts or repair service, please contact a *Giles Manufacturer's Representative* to assist with locating a source near you ... their contact information is available on the *Giles website*. For further assistance you may contact the **Giles Services Team** as follows:

IN THE UNITED STATES & CANADA call: 800.554.4537

ALL OTHERS call: 334.272.1457



Normal business hours are **8:00 AM to 5:00 PM Central Time** ... your call will be handled by an automated phone system ... please follow the recorded instructions to reach the appropriate party or department.

When calling outside of normal hours, leave a voice message including your contact information & a brief description of your issue ... a *Services representative* will promptly return your call, *usually within thirty (30) minutes*.

You can also email ... services@gfse.com ... you may also find useful information on our website: www.gfse.com

Giles goal is to provide the highest possible quality of service and assistance. To help us accomplish this, please have the following information readily available when calling, along with a brief description of the problem being experienced. Please record the unit information in the table below for quick reference.

Model:	
Serial Number:	
Voltage:	
Phase:	

MODEL/MODELE		SERIAL NO/NO. DE SERIE		
GEF-720		70848 011713 05		
VAC/VCA	HZ	PHASE	AMPS	WATTS
208	60	3	58	20000
DESCRIPTION/DESCRIPCIÓN				
FRYER, GEF-720, COMP, 208/60/3				
				
GILES ENTERPRISES 1-800-554-4537 2750 GUNTER PARK DRIVE WEST • MONTGOMERY • ALABAMA • 36109				

The information can be found on the Serial/Data Label located inside the fryer cabinet or on rear cabinet panel.

7.2 Front Header & Control Panel

FRONT HEADER PANEL

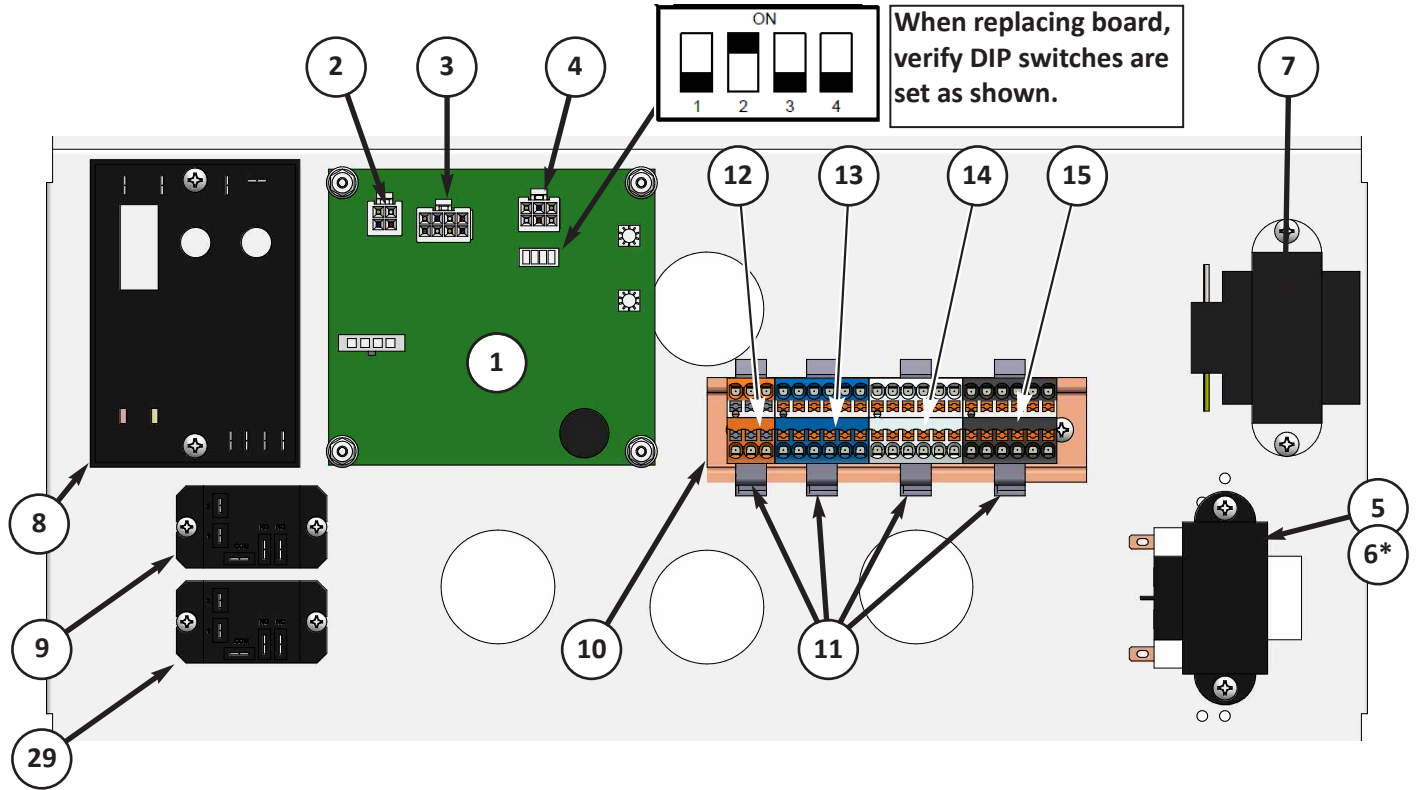

FRONT CONTROL PANEL

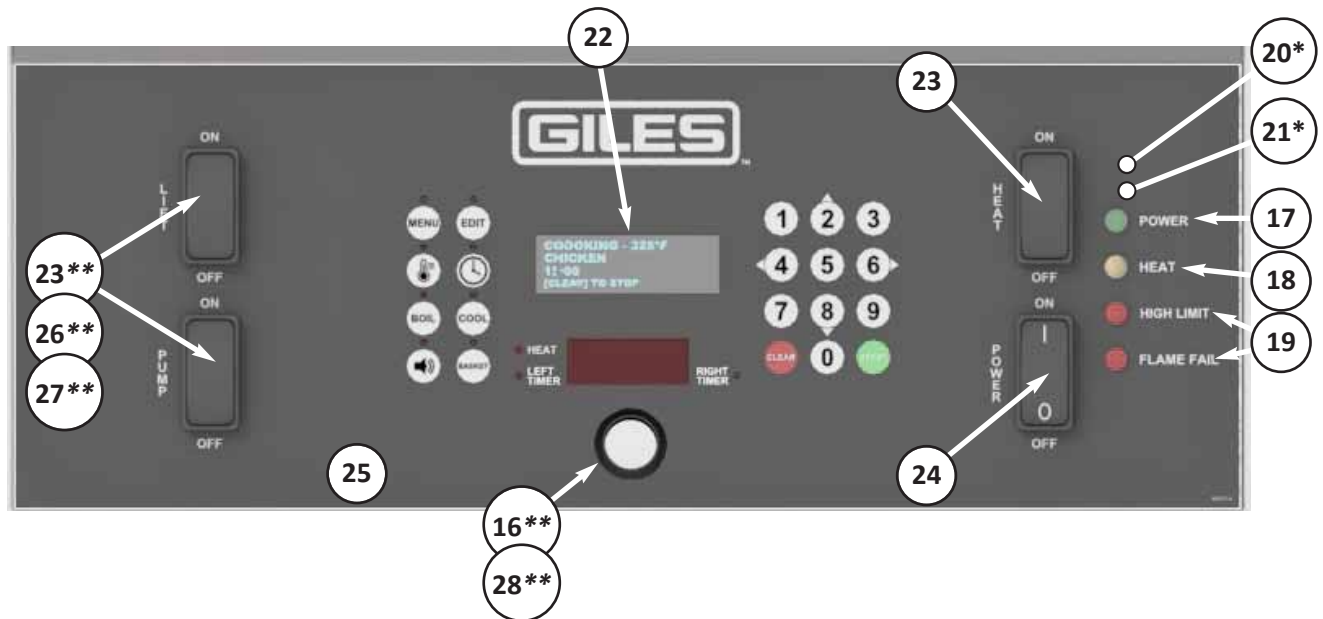

* Not Shown ... back side of panel

** Part may **NOT** be present, depending on installed fryer options ... holes will be plugged w/Items (26 - 27) or 28

7.2 Front Header & Control Panel

Item	Part Number	QTY.	Description
1	21237	1	BLOWER CONTROL, UGM BOARD (EBM)
2	21267	1	WIRE HARNESS, J6,UGA CONTROL (EBM)
3	21268	1	WIRE HARNESS, J5,UGB CONTROL (EBM)
4	21383	1	WIRE HARNESS, J3, CONTROLLER (EBM)
5	20366	1	TRANSFORMER, 20VA, 115/230V, 60HZ, CL2
6*	38365	1	IN-LINE FUSE ASSY, CONTROLLER, 1.5A, INSULATED
7	21503	1	TRANSFORMER, 40VA TO 24VCT, 115/230V
8	21584	1	TEMP. LIMIT SAFETY CONTROL BOARD, 515° F
9	21472	1	RELAY, FORM C, 30A, 120VAC COIL
10	91862	1	DIN RAIL, 5"
11	21496	4	DIN RAIL CLIP, END BRACKET, PTFIX, NS-35
12	21507	1	DIST. BLOCK, 6-PL, 12-26 AWG, ORANGE
13	21513	1	DIST. BLOCK, 12-PL, 12-26 AWG, BLUE
14	21511	1	DIST. BLOCK, 12-PL, 12-26 AWG, WHITE
15	21510	1	DIST. BLOCK, 12-PL, 12-26 AWG, BLACK
16**	21555	1	SWITCH, PUSHBUTTON, MOMENTARY, 10A
17	21678	1	GREEN INDICATOR LIGHT, 125-250V
18	21682	1	AMBER INDICATOR LIGHT, 24V
19	21683	2	RED INDICATOR LIGHT, 24V
20*	96443*	1	BRACKET, INDICATOR LIGHTS
21*	96444*	2	SPACER PLATE, INDICATOR LIGHTS
22	21374	1	FRYER CONTROLLER, DUAL TIMER, CC10
23	21052**	1 (2) (3)**	SWITCH, ROCKER, ON-OFF-ON, 250V,20A,S.P.
24	21190	1	SWITCH, ROCKER, ON-OFF, 250V, 20A, D.P.
25	66151	1	LABEL, CONTROL PANEL, GBF-80G
26**	20621	(1) (2)	PLUG, SWITCH CUT-OUT
27**	41454	(1) (2)	GASKET, SWITCH
28**	21556	1	PLUG, PUSH-BUTTON SWITCH
29	21742	1	RELAY, NO-NC, 30A-20A, 277VAC, 24VAC COIL

* Not Shown ... back side of panel

** Part may **NOT** be present, depending on installed fryer options ... holes will be plugged w/Items (26 - 27) or 28

7.3 Front Lower Cabinet - Single Fryer

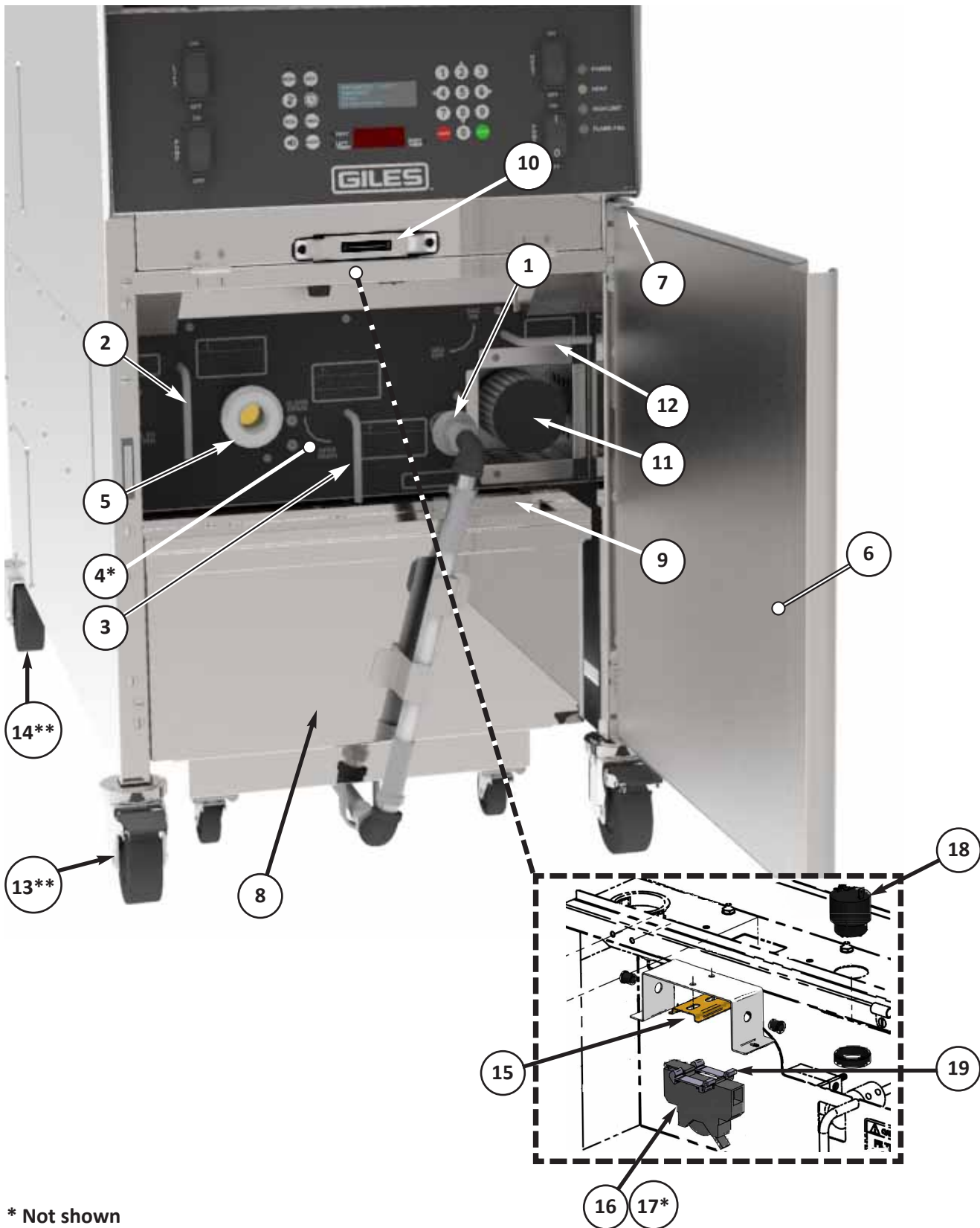

* Not shown

** (3) required for 2-well unit ... (4) required for 3-well

7.3 Front Lower Cabinet - Single Fryer

Item	Part Number	Qty	Description
1	41900	1	FITTING, QUICK-COUPLING, FEMALE (<i>FILTER PAN HOSE</i>)
2	96613	1	<u>DIVERTER VALVE</u> HANDLE
3	99615	1	<u>DRAIN VALVE</u> HANDLE
4*	21386	2	LIMIT SWITCH, DRAIN SAFETY INTERLOCK (<i>BEHIND PANEL</i>)
5	41699	1	FITTING, QUICK-COUPLING, FEMALE (<i>DISCHARGE HOSE</i>)
6	96435	1	DOOR WELD ASSY, GBF-80G
7	98515	1	DOOR HINGE, TOP (<i>ATTACHED TO DOOR</i>)
8	97901	1	FILTER PAN ASSEMBLY, COMPLETE (<i>SEE SECTION 7._ FOR PARTS</i>)
9	96659	1	FILTER PAN COVER
10	40851	1	CATCH, MAGNET, DOOR, SNAP IN, 2.3IN
11	41397	1	INTAKE AIR FILTER
12	96617	1	GAS VALVE HANDLE, GBF-80G
13**	40704	2 (3) (4)	CASTER, SWIVEL, 4.5", w/BRAKE, STEM MOUNT
14**	40641	2 (3) (4)	CASTER, SWIVEL, 4.5", STEM MOUNT
15	98335	1	DIN RAIL, 2"
16	20411	1	FUSE HOLDER, DIN RAIL, 600V, 32A
17*	21693	1	FUSE, 15A, 1.5", CLASS C
18	22976	1	SONALERT, CONTINUOUS, 2-12 VDC
19	21496	2	DIN RAIL CLIP, END BRACKET, PTFIX, NS-35

7.4 Rear Cabinet - Gas Plumbing

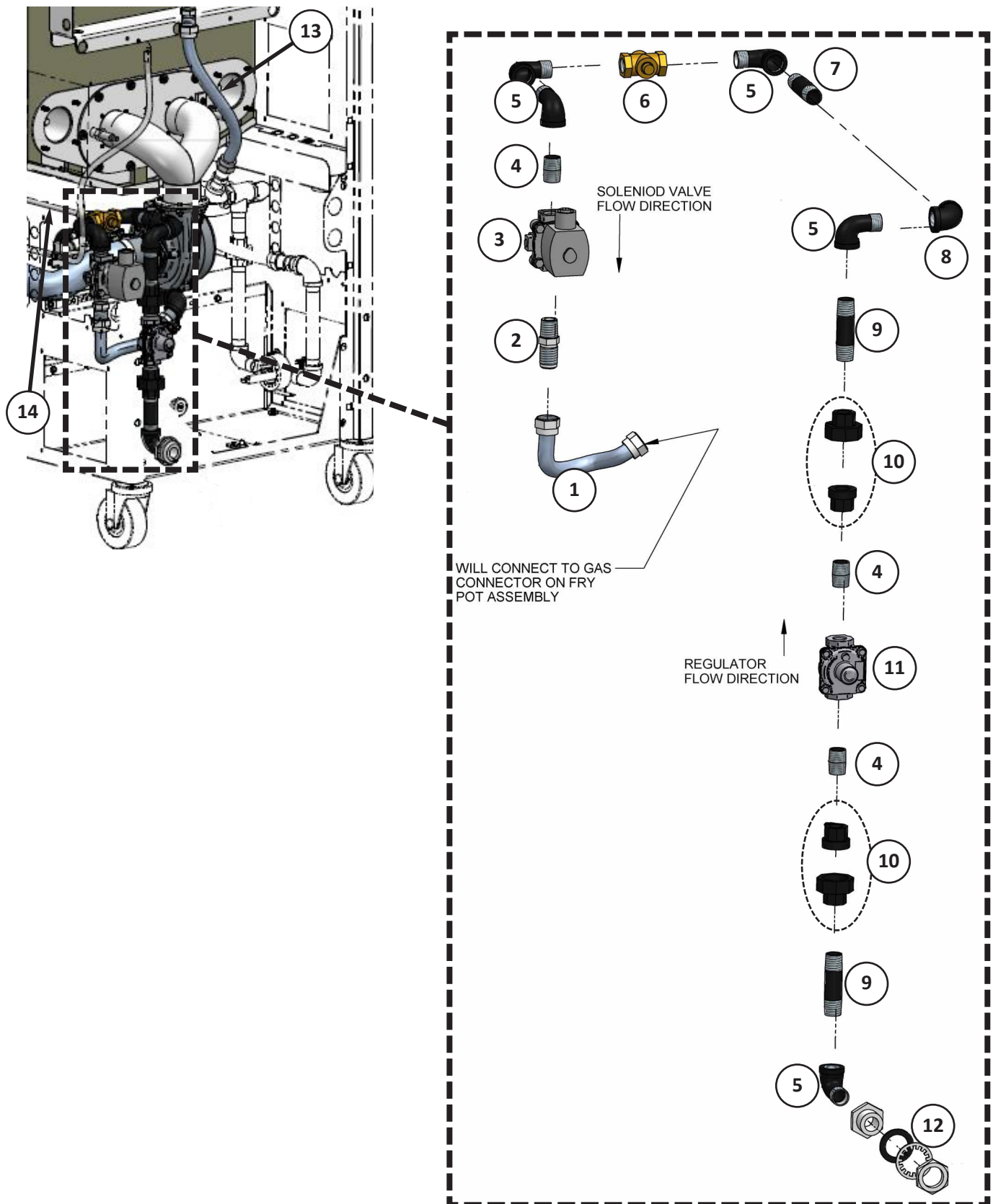

7.4 Rear Cabinet - Gas Plumbing

Item	Part Number	Qty.	Description
1	41079	1	HOSE, CORRUGATED, SS, 1/2" ID X 8"
2	40889	1	ADAPTER, 1/2-COMPRESS TO 1/2-NPT
3	21371	1	SOLENOID VALVE, GAS, 1/2"
4	43850	3	NIPPLE, 1/2", CLOSE, BLACK PIPE
5	42250	5	90-DEG ELL, 1/2", STREET, BLACK PIPE
6	34955	1	VALVE, 1/2", MODIFIED GAS COCK
7	40175	1	NIPPLE, 1/2" X 3-1/4", BLACK PIPE
8	42200	1	90-DEG ELBOW, 1/2" NPT, BLACK PIPE
9	43950	2	NIPPLE, 1/2" X 3", BLACK PIPE
10	45575	2	UNION, 1/2", BLACK PIPE
11	41468	1	PRESS. REGULATOR, NAT GAS, 1/2"-NPT
	41472	1	PRESS. REGULATOR, LP GAS, 1/2"-NPT
12	46475	1	ADAPTER, QUICK-SEAL, 1/2"
13	40909	1	HOSE, CORRUGATED, SS, 1/2-NPT X 15"
14	96617	1	GAS VALVE HANDLE, GBF-80G

7.5 Rear Cabinet - Oil Pump Plumbing

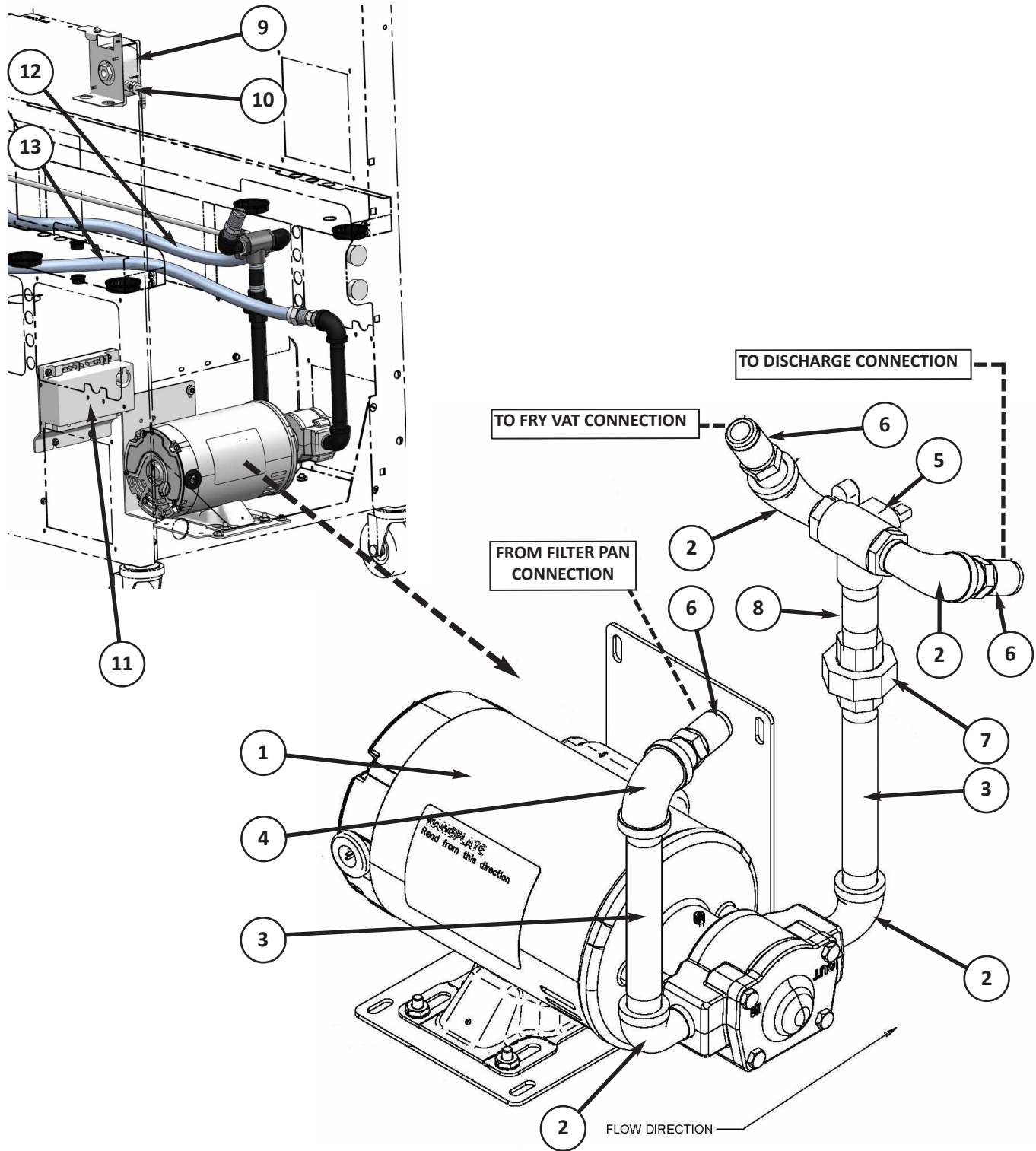

7.5 Rear Cabinet - Oil Pump Plumbing

Item	Part Number	Qty.	Description
1	71754	1	PUMP & MOTOR ASSEMBLY, 5-GPM, 1/2 HP
	76923	1	PUMP HEAD ONLY, 5-GPM
	71824	1	MOTOR ONLY, 1/2 HP
2	42250	4	STREET ELL, 90-DEG, 1/2"
3	42001	2	NIPPLE, 1/2" X 6", BLACK PIPE
4	42200	1	ELBOW, 90-DEG, 1/2" NPT, BLACK PIPE
5	45755	1	VALVE, 3-WAY, 1/2NPT, NICKEL PLATED
6	40889	4	ADAPTER, 1/2" COMPRESSION X 1/2" PIPE THREAD
7	45575	1	UNION, 1/2", BLACK PIPE
8	46753	1	NIPPLE, 1/2" X 2-1/2", BLACK PIPE
9	20390	1	SWITCH, VACUUM, DUNGS, 0.16 - 1.20 WC
10	40877	1	FITTING, 1/4" BARBED, 90-EL, NYLON, 1/8" NPT
11	21240	1	IGNITION MODULE, 24VAC, FENWAL
12	41080	1	HOSE, CORRUGATED, SS, 1/2" ID X 20"
13	41081	1	HOSE, CORRUGATED, SS, 1/2" ID X 30"

NOTE:

Multi-well models contain only one pumping system.

7.6 Rear Cabinet - Header - Optional Basket Lifts

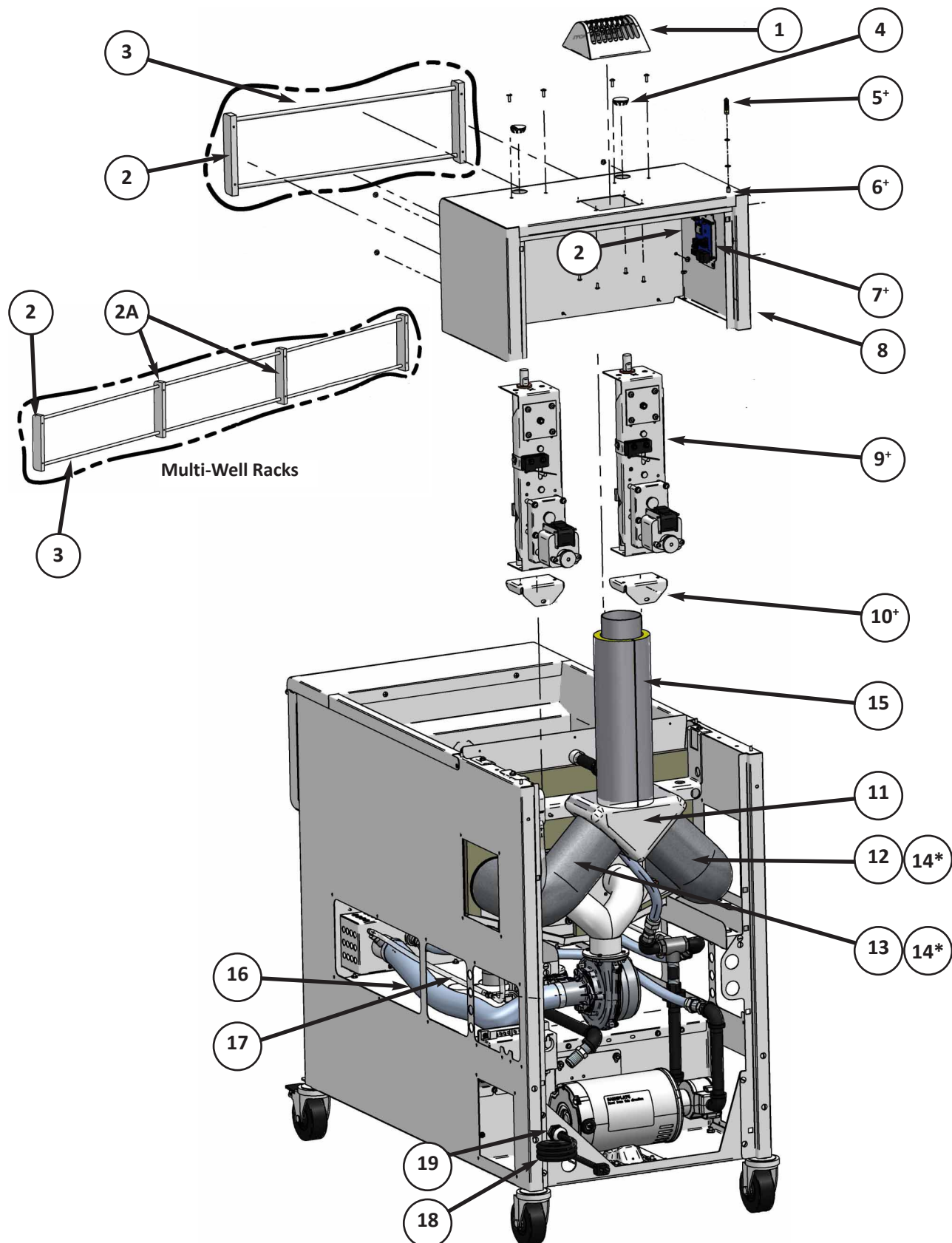

7.6 Rear Cabinet - Header - Optional Basket Lifts

Item	Part Number	Qty.	Description
1	97857	1	EXHAUST STACK COVER
2	35088	2	BAR, OUTSIDE BASKET RACK (STANDARD) ... ALL
2A	35087	1	BAR, MIDDLE BASKET RACK (STANDARD) ... 2-WELL FRYER
		2	BAR, MIDDLE BASKET RACK (STANDARD) ... 3-WELL FRYER
3	99222	2	ROD, BASKET RACK (STANDARD) ... SINGLE FRYER
	99218	2	ROD, BASKET RACK (STANDARD) ... 2-WELL FRYER
	99223	2	ROD, BASKET RACK (STANDARD) ... 3-WELL FRYER
4	10109	2	HOLE PLUG, 1-1/8", NICKEL PLATED (STANDARD)
5 ⁺	21613 ⁺	1	ANTENNA, WIFI, 2.4GHz, RP-SMA, 1.8dB (OPTIONAL* KITCHENTRAC®)
6 ⁺	21614 ⁺	1	CABLE, RF, U.FL TO RP-SMA, 15" (OPTIONAL* KITCHENTRAC®)
7 ⁺	21606 ⁺	1	WIFI BOARD ASSEMBLY, EXT. ANTENNA (OPTIONAL* KITCHENTRAC®)
8	96761	1	TOP HEADER (GBF-80G)
	98538	1	TOP HEADER (GBF-80/80G)
	98653	1	TOP HEADER (GBF-80/80/80G)
9 ⁺	96623 ⁺	2	BASKET LIFT ASSEMBLY (OPTIONAL*)
10 ⁺	97523 ⁺	2	BASKET LIFT MOUNT BRACKET (OPTIONAL*)
11	96471	1	EXHAUST TUBE ASSEMBLY
12	98003	1	RIGHT EXHAUST TUBE ASSEMBLY (REQUIRES 2 GASKETS, #14)
13	97445	1	LEFT EXHAUST TUBE ASSEMBLY (REQUIRES 2 GASKETS, #14)
14	96745	4	GASKET, EXHAUST TUBE
15	46767	VAR	INSULATION, 1/2", CERAMIC FIBER, FOIL BACK (WRAP ALL EXHAUST TUBES)
16	96609	1	AIR INTAKE HOSE, 1-3/4" X 23" (REINFORCED THERMOPLASTIC RUBBER)
17	96617	1	GAS VALVE HANDLE, GBF-80G
18	21285	1	CORDSET, SJOOW, 18/3, NEMA 5-15P, 120V
19	21372	1	CONNECTOR, SO CORD, 1/4" TO 3/8"

NOTE:

Except where noted, component quantities are for single unit fryers ... in most incidences the quantities for 2 & 3-well units are generally multiples of these quantities.

* Not Shown

+ Optional Items

7.7 Cook Vat & Burner Assembly

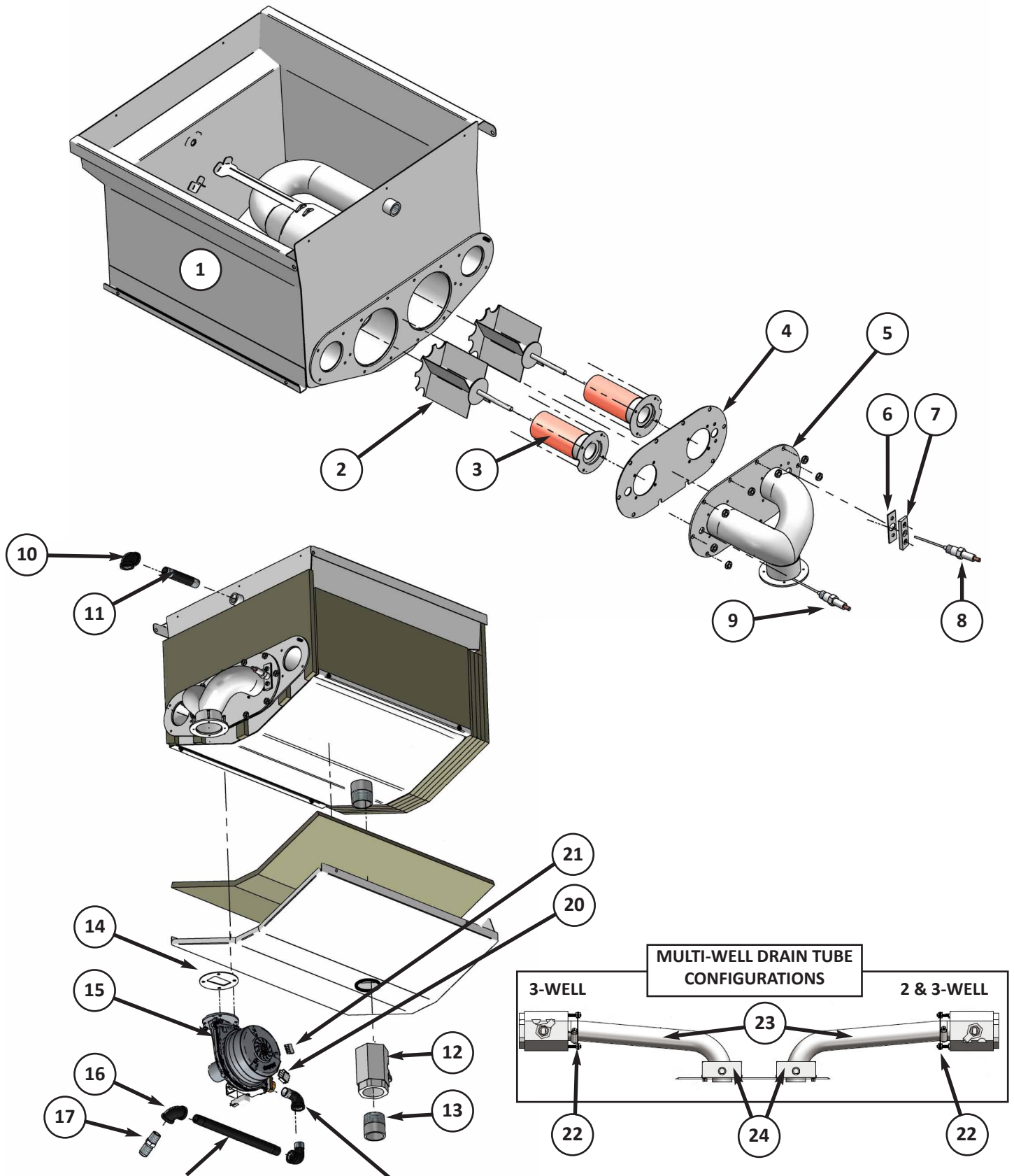

7.7 Cook Vat & Burner Assembly

Item	Part Number	Qty.	Description
1	96284	1	COOK PAN WELD ASSEMBLY (ONLY AVAILABLE AS COMPLETE ASSY)
2	97571	2	HEAT BAFFLE, LARGE TUBE
3	41253	2	GAS BURNER, SS MESH CLOTH
4	96486	1	GASKET, INTAKE MANIFOLD
5	95157	1	INTAKE MANIFOLD
6	96487	1	GASKET, IGNITOR
7	96608	1	MOUNTING BLOCK, IGNITOR
8	21369	1	SPARK IGNITOR, AUBURN I-143
9		1	FLAME SENSOR, AUBURN I-143
10	42200	1	ELBOW, 1/2-NPT, 90-DEG, BLACK PIPE
11	31435	1	NIPPLE, 1/2 X 4", BLACK PIPE
12	45876	(1) (2) (3)	DRAIN VALVE, 1-1/2 NPT (MULTI-WELL VALVES REQ. #41512, STREET ELL)
13	40895	1	NIPPLE, TOE, 1-1/2 NPT X 2"
14	98004	1	GASKET, BLOWER
15*	98025*	1	GAS PRE-MIXER/BLOWER ASSEMBLY
16	42200	1	ELBOW, 90-DEG, 1/2" NPT, BLACK PIPE
17	40889	1	ADAPTER, 1/2" COMPRESSION X 1/2" PIPE THREAD
18	32621	1	NIPPLE, 1/2" X 10-1/4", BLACK PIPE
19	42250	2	STREET ELL, 90-DEG, 1/2"
20	21263	1	WIRING HARNESS, 3-PIN, EBM BLOWER
21	21264	1	WIRING HARNESS, 5-PIN, EBM BLOWER
22	93014	(1) (2)	FLANGE, DRAIN TUBE, MULTI-WELL ONLY
23	41515	(1) (2)	TUBE, DRAIN, FORMED, MULTI-WELL ONLY
24	99219	(1) (2)	BRACKET, DRAIN PIPE, HOLD-DOWN, MULTI-WELL ONLY

* Component Assembled & Tuned at Factory

NOTE: The small heat exchanger tubes contain heat transfer baffle fin assemblies ... these assemblies are NOT field replaceable ... **DO NOT** attempt to remove. If there is evidence that the fins have become obstructed enough to create inadequate airflow through the heat exchanger, the only repair solution is replacement of the entire cook vat assembly.

7.8 Cook Vat - Probe Layout

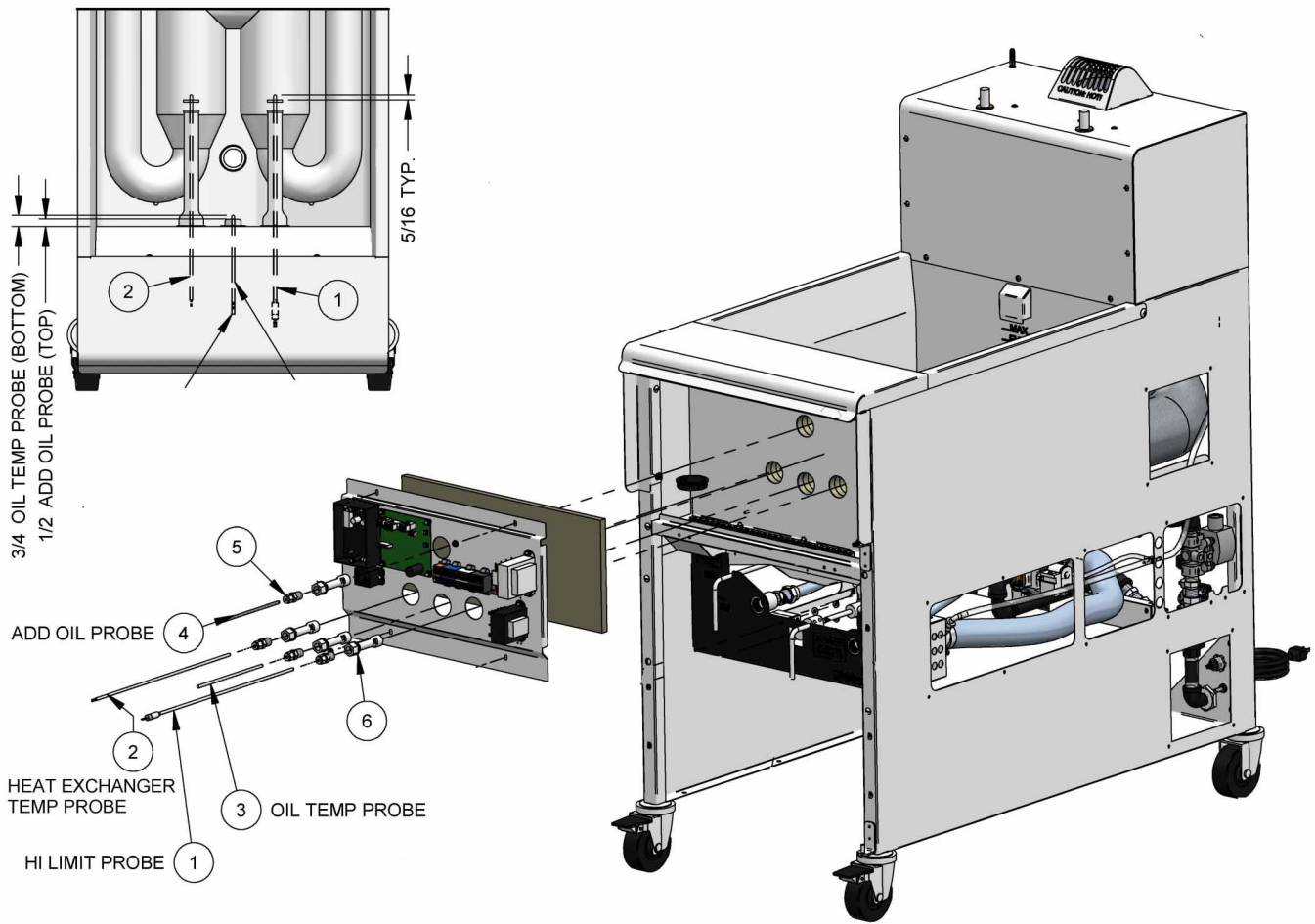

7.8 Cook Vat - Probe Layout

Item	Part Number	Qty.	Description
1	21599	1	THERMOCOUPLE, J-TYPE, DUAL, UNGROUNDED, 13-1/2"
2	20315	1	THERMOCOUPLE, J-TYPE, UNGROUNDED, 13-1/2"
3	20534	1	THERMOCOUPLE, J-TYPE, GROUNDED, 6-1/2"
4	21382	1	THERMOCOUPLE, J-TYPE, UNGROUNDED, 5-1/2"
5	45400	4	CONNECTOR, 0.190 ID, 1/4-NPT, SWAGELOCK
6	97556	4	BARREL NUT, 1/4-18 NPT
7	21386	2	LIMIT SWITCH, DRAIN SAFETY INTERLOCK

7.9 Filter Pan Assembly

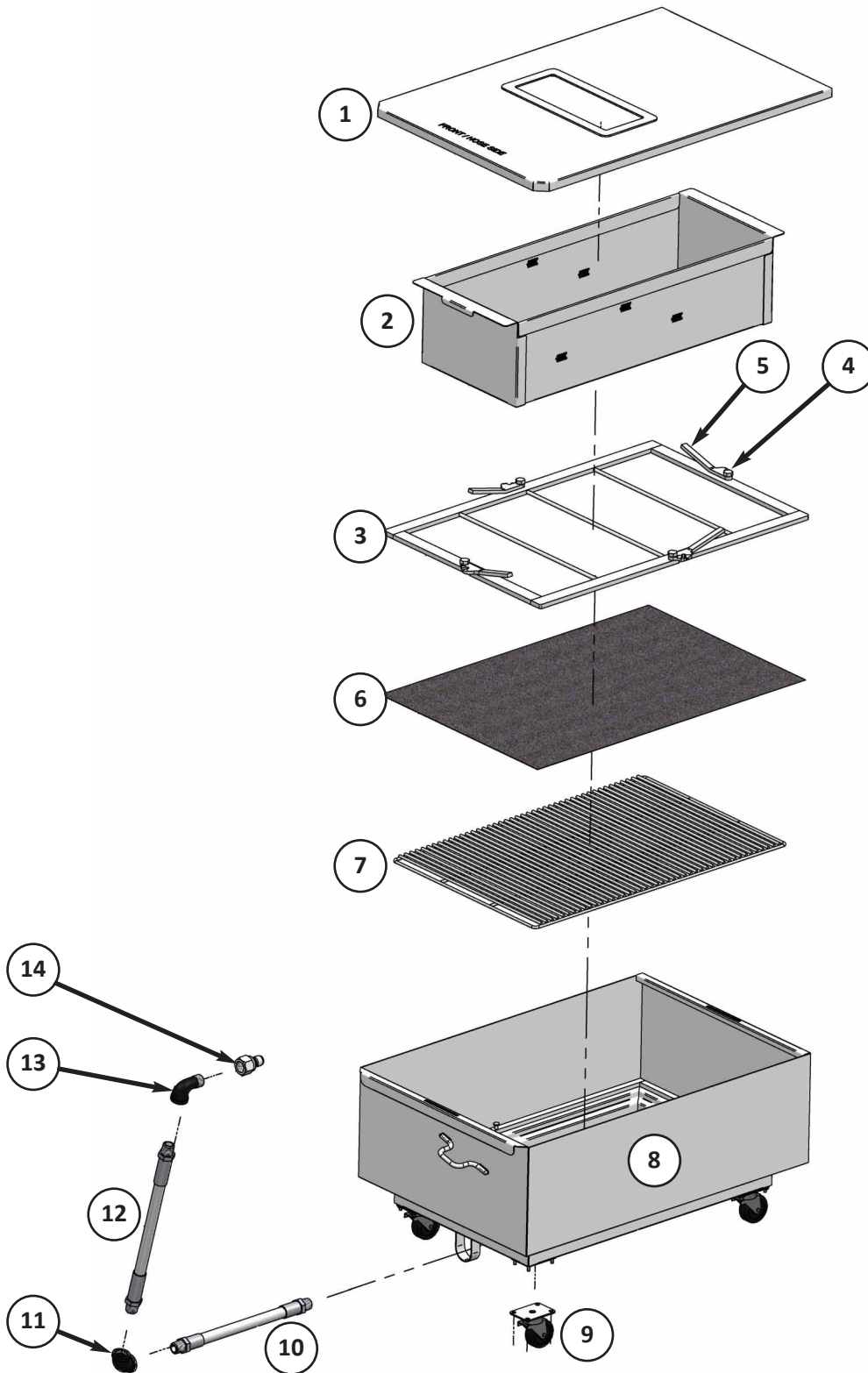

7.9 Filter Pan Assembly

Item	Part Number	Qty.	Description
1	96659	1	FILTER PAN COVER
2	97613	1	CRUMB SCREEN
3	30040-5	1	HOLD-DOWN FRAME
4	30040-4	4	STUD, FILTER PAN HOLD DOWN FRAME
5	54526	4	HOLD-DOWN FRAME LEVER
6	60819	1	FILTER PAPER, 16-1/4" X 24-1/4", GFSE
7	97900	1	MEDIA SUPPORT SCREEN, FILTER PAN
8	97891	1	FILTER PAN, WELD ASSEMBLY
9	40649	4	CASTER, 2", LOW PROFILE, FILTER PAN
10	41073	1	HOSE, 1/2 NPT X 12-1/2, SCT, SWIVEL FITTINGS
11	42200	1	ELL, BLACK, 1/2, 90-DEG
12	40690	1	HOSE, 1/2-NPT X 14-1/8", SCT, 1-END SWIVEL
13	42250	1	ELL, 1/2, 90-DEG, STREET, BLACK PIPE
14	44150	1	FITTING, S/S, 1/2-NPT, MALE QUIK-CONNECT

COMPLETE ASSEMBLY - 97901 ... includes all above

7.10 Baskets, Panels & Covers

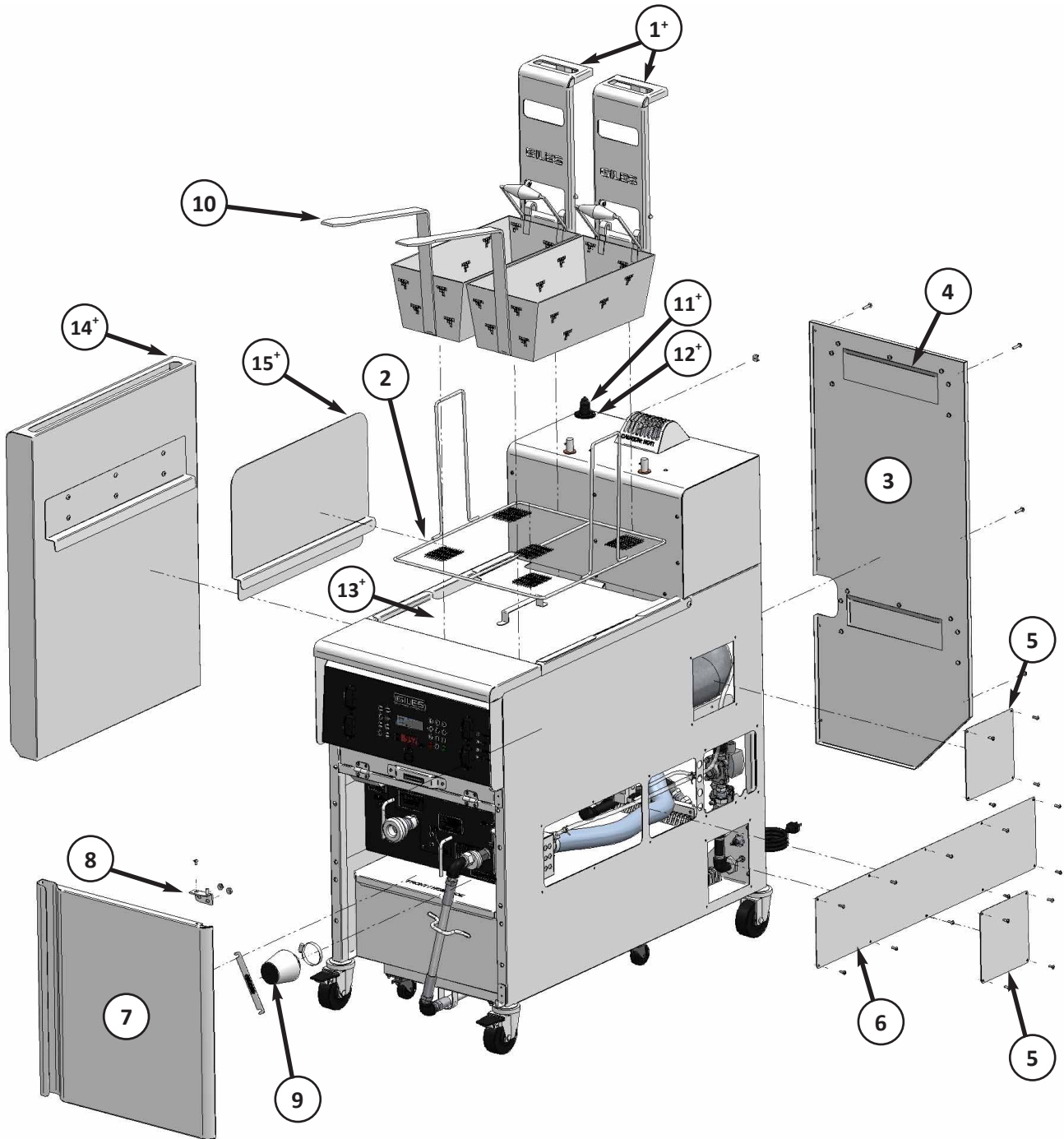

7.10 Baskets, Panels & Covers

Item	Part Number	Qty.	Description
1 ⁺	96409	2	BASKET CARRIER ASSEMBLY (<i>OPTIONAL</i>)
2	41622	1	VAT CRUMB SCREEN
3	96426	1	PANEL, CABINET BACK
4	96427	2	SHIELD, BACK PANEL
5	96431	4	CABINET SIDE COVER, SMALL
6	97447	2	CABINET SIDE COVER, LONG
7	96435	1	CABINET DOOR
8	98515	1	DOOR HINGE, TOP
9	41397	1	AIR INTAKE FILTER (<i>CONSUMABLE ITEM</i>)
10	70420	2	COOK BASKET, W/ REAR HANDLE
11 ⁺	21696	1	RADOME, WIFI ANTENNA COVER (<i>OPTIONAL, WIFI ONLY</i>)
12 ⁺	99668	1	GASKET, RADOME (<i>OPTIONAL, WIFI ONLY</i>)
13 ⁺	80177	1	POT COVER (<i>OPTIONAL</i>)
14 ⁺	72067	1	TOOL CADDY / SPLASH SHIELD (<i>OPTIONAL</i>)
15 ⁺	72096	1	SPLASH SHIELD (<i>OPTIONAL</i>)

7.11 Optional Parts: Multi-Well Units Only

A. Fryer w/Oil Top-Off Option

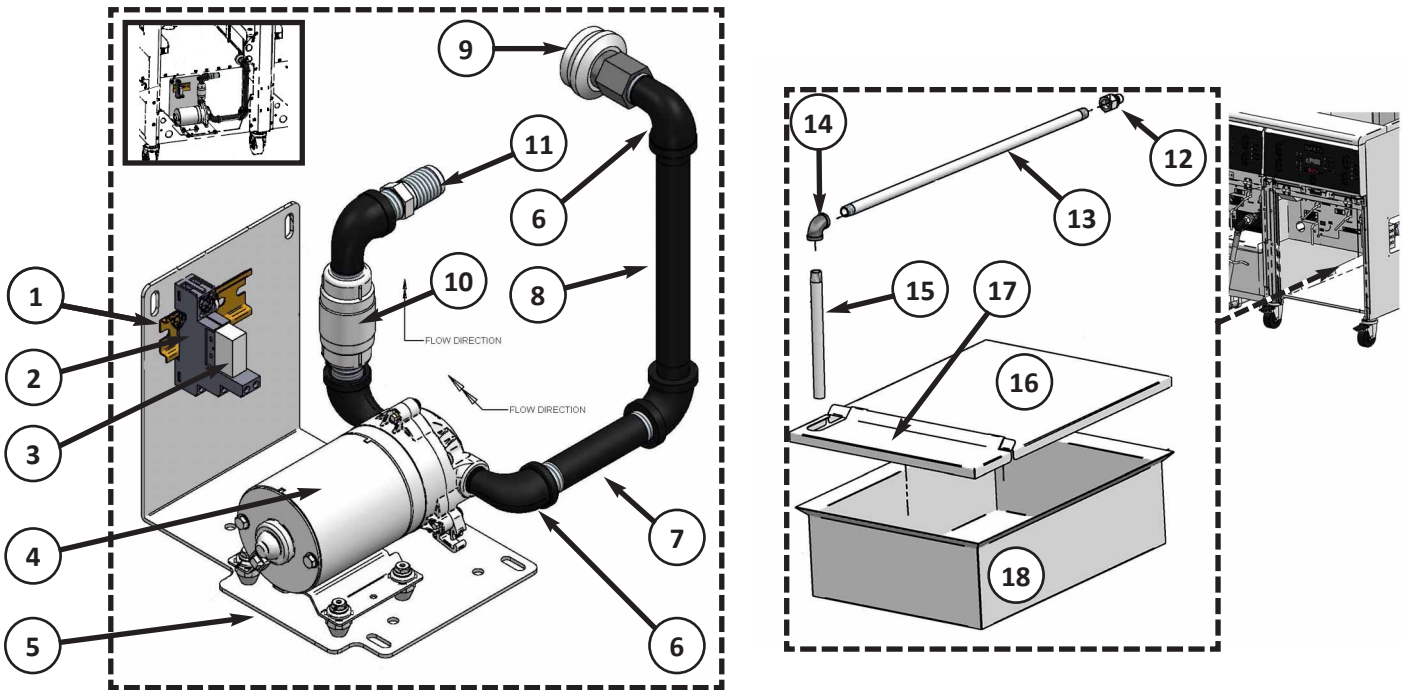

B. Fryer w/Fresh Bulk Oil Option

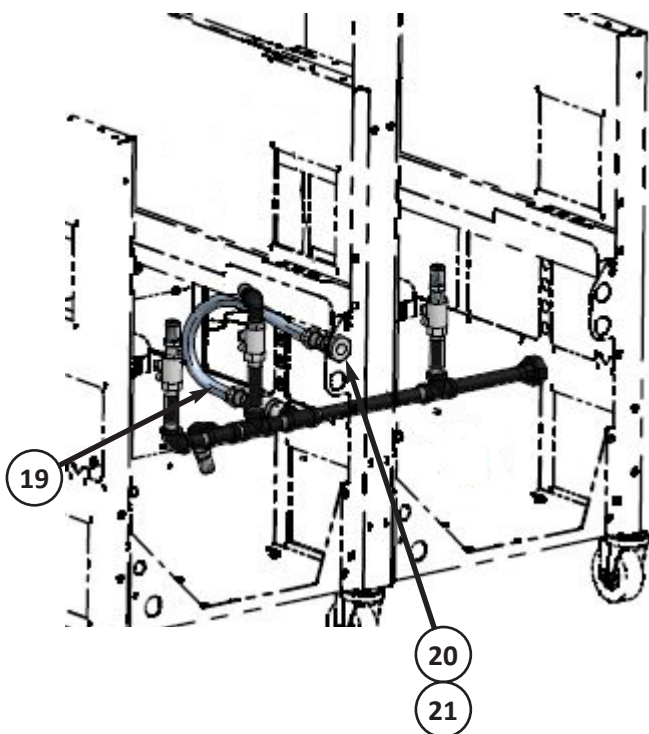

C. Fryer w/Bulk Waste Oil Option

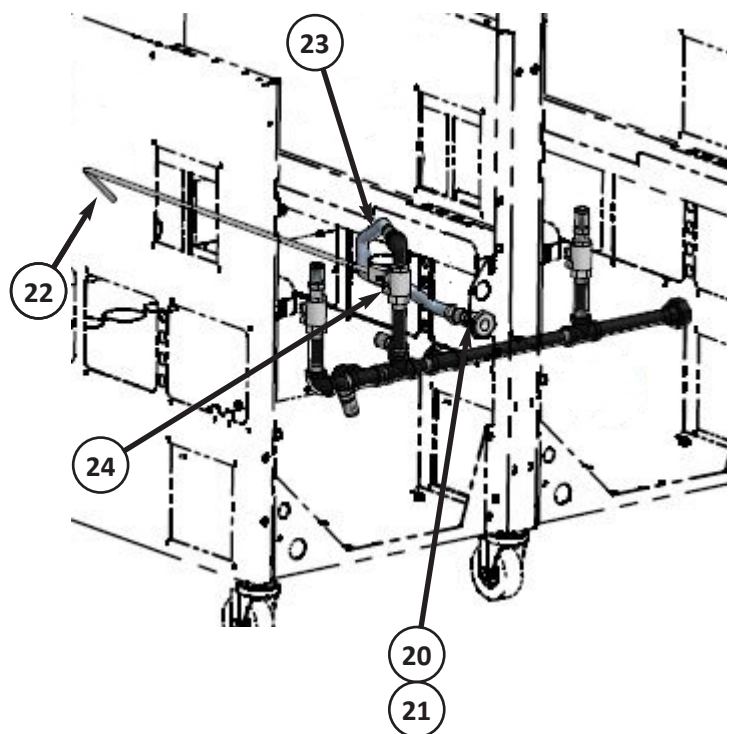

7.11 Optional Parts: Multi-Well Units Only

Item	Part Number	Qty.	Description
1	94784	1	DIN RAIL, 3"
2	21438	1	SOCKET RELAY, DIN MOUNT, 250V, 10A
3	21463	1	RELAY, SPDT, 250V, 24V COIL, 16A
4	21612	1	PUMP, ADD OIL, 1/2-NPT, 115V
5	96423	1	MOUNTING BRACKET, TOP-OFF PUMP
6	42250	4	ELL, 1/2, 90-DEG, STREET, BLACK
7	34963	1	NIPPLE, 1/2-NPT X 4-1/2, BLK PIPE
8	44075	1	NIPPLE, 1/2 X 7-3/4, BLACK PIPE
9	41900	1	COUPLING, QUICK-COUPLER, FEMALE
10	46712	1	CHECK VALVE, 1/2NPT
11	40889	1	ADAPTER, 1/2-COMPRESS TO 1/2-NPT
12	44150	1	FITTING, 1/2NPT, QUICK-COUPLER, MALE
13	41517	1	NIPPLE, 1/2NPT X 30", STAINLESS
14	42252	1	ELBOW, 90-DEG, 1/2NPT, STAINLESS
15	41516	1	NIPPLE, TOE, 1/2NPT X 10", STAINLESS
16	98626	1	COVER, REAR, OIL RESERVOIR (TOP-OFF OPTION)
17	98629	1	FRONT COVER, OIL RESERVOIR (TOP-OFF OPTION)
18	98625	1	PAN, OIL RESERVOIR (TOP-OFF OPTION)
19	41080	1	HOSE, CORRUGATED, SS, 1/2 ID X 20"
20	46475	(1) (2)	ADAPTER, 1/2, QUICK-SEAL
21	40889	(1) (2)	ADAPTER, 1/2-COMPRESS TO 1/2-NPT
22	98543	1	WASTE VALVE HANDLE (BULK WASTE OIL OPTION)
23	41080	1	HOSE, CORRUGATED, SS, 1/2 ID X 20"
24	40784	1	VALVE, BALL, 1/2, S/S W/NO-STICK SEALS

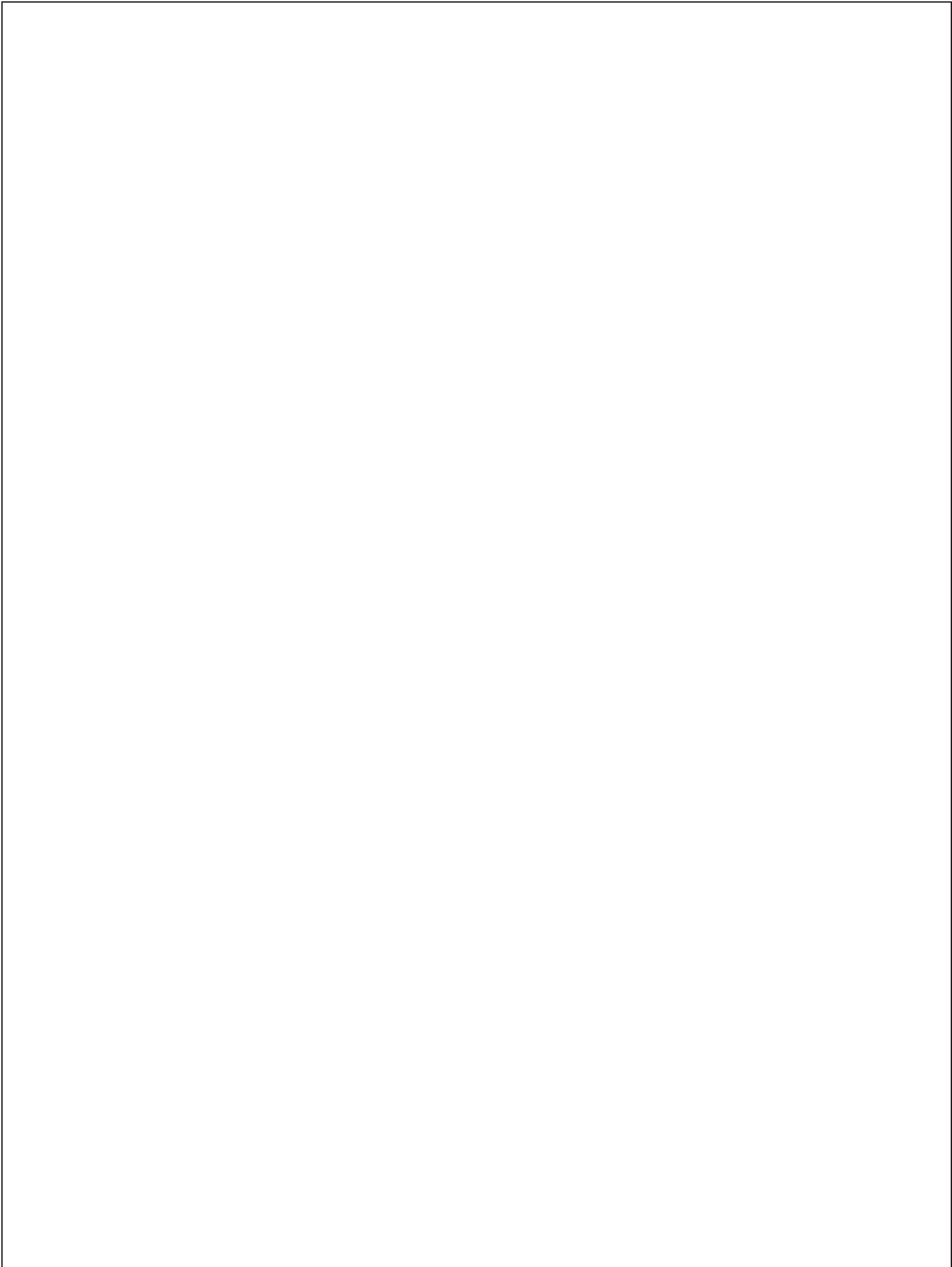



GILES Food Service Equipment
ISO 9001-2015 Certified

2750 Gunter Park Drive West • Montgomery, AL 36109 USA
Phone 334.272.1457 • Fax 334.239.4117 • Phone Toll Free 800.554.4537
Website: www.gfse.com • Email: services@gfse.com

66307
REV-C
ECO3332
9/25/2024
PRINTED IN USA