



Project Name/No: _____ Item No: _____
Quantity: _____ SIS#: _____ AIA/CSI#: _____

Portable Waste Oil Caddy

Model GOC



The **GILES Waste Oil Caddy** provides food service operators a convenient means to safely remove used cooking oil from fryers and then move it to a designated disposal/recycle site.

- Capacity to hold approximately **80 lbs** of waste oil ... approx. (2) mid-size fryers.
- Manually operated rotary pump ... no hassle with power cords & electrical outlets.
- Pump operates in either direction ... one direction discharges oil from tank ... turning the opposite direction can provide suction at the wand, if needed.
- Durable stainless steel construction ... welded tank.
- Large 8" wheels makes maneuvering & handling easy, even when full.

Portable and efficient ... save time & money. The perfect solution to handling your waste cooking oil.

Design Features:



Equipped with a sight glass which provides an easy-to-see indication when the oil level is approaching full ... helps preventing over-filling & spillage.

Capacity:

Volume to hold waste oil from two (2) medium size fryers (approx. 80 lbs).

Hinged Lid w/Latch:

Holes in lid are trimmed with rubber grommets to provide a receptacle for the fryer's discharge hose wand while pumping waste oil into tank.

Holds the hose wand after pumping is complete so that it drains into tank rather than dripped onto the floor.



GILES Food Service Equipment ▪ ISO 9001 Registered

PO Box 210247; 2750 Gunter Park Drive W; Montgomery, AL 36109 USA
334.272.1457 ▪ Fax 334.239.4117 ▪ Toll Free 800.554.4537 (US/Canada Only) ▪ www.gfse.com ▪ Email: services@gfse.com

Printed in USA, Form 65776 (Rel.Date: Apr.2003) Rev: Sep.2010, Rev. C

Portable Waste Oil Caddy

GOC

Project Name/No: _____ Item No: _____

Quantity: _____ SIS#: _____ AIA/CSI#: _____

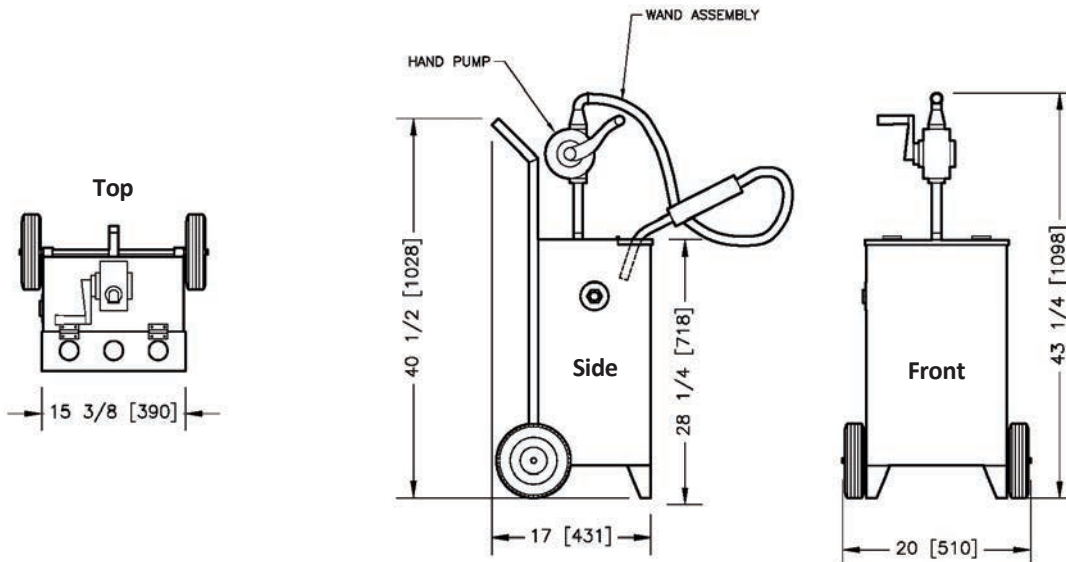

Inches [mm]

Specifications

Construction: Tank - 16 & 18 ga. welded stainless steel ... Handle - 16 ga. 1" sq. stainless steel tube

Dimensions:

Width	Depth	Height	Floor Space
20" [508 mm]	17" [432 mm]	43-1/4" [1099 mm]	2.4 sq.ft [0.2 sq.m]

Operating Temperature:

Max. Temp = 350°F [177°C]

Min. Temp = 100°F [38°C] to 200°F [93°C]

(Designed to handle ONLY warm filtered oil)

Capacity:

Holds up to 80 lbs [36 kg] of waste cooking oil.

Shipping Specifications:

Width	Depth	Height	Cube	Crated Weight
21" [534 mm]	18" [457 mm]	46" [1169 mm]	10 cu ft [0.3 cu m]	67 lbs [137 kg]

How To Specify

1. Ordering Options

Specify part number from the following:

✓	Model	Item Number
	GOC	79187

2. Shipping

Specify preferred shipping method

Typically ships via Parcel Service.



2750 Gunter Park Drive West • Montgomery, AL 36109 USA
334.272.1457 • Toll Free: 800.554.4537

Product specifications and/or designs are subject to changes without notice. Such revisions do not entitle the buyer to corresponding changes, improvements, additions or replacements for previously purchased equipment.