



PROVEN & TRUSTED SINCE 1952

Project Name/No: \_\_\_\_\_ Item No: \_\_\_\_\_

Quantity: \_\_\_\_\_ SIS#: \_\_\_\_\_ AIA/CSI#: \_\_\_\_\_

## Portable Landing Table

LT-3



Using the versatile **Portable LT-3 Landing Table**, can help create all of the extra workspace you may need in the kitchen!

- Multi-functional, highly portable utility cart & fryer dump station combination.
- Convenient portable fryer dumping station for cooked product. Open-front *Holding Pan* for easy loading & unloading. Accommodates an 18" x 26" Sheet Pan with a provided glazing screen to aid product drainage.
- When needed, remove the *holding pan* to create an additional worktable, or cart to transport food service pans, soiled dishes/utensils, etc.
- Easily removable *Center Shelf* is standard.
- Constructed of durable stainless steel with robust 4-1/2" swiveling casters for easy maneuverability. All wheels have brakes to create a stable workstation, when needed.
- Alternative *Side Racks*; each level accommodates a full-size sheet pan. Racks mount & lift off easily without tools.

### Design Features:



#### Removable Side Racks

Alternative side racks - slide in up to (6) sheet pans for added storage ... makes the **LT-3** a must have for any foodservice operation.

**GILES Food Service Equipment** • ISO 9001 Registered

PO Box 210247; 2750 Gunter Park Drive W; Montgomery, AL 36109 USA

334.272.1457 • Fax 334.239.4117 • Toll Free 800.554.4537 (US/Canada Only) • [www.gfse.com](http://www.gfse.com) • Email: [services@gfse.com](mailto:services@gfse.com)

Printed in USA, Form 67380.E, Rel.Date: Nov.2011, Rev. Date: Jan.2018, Rev. E

# Portable Landing Table LT-3

Project Name/No: \_\_\_\_\_ Item No: \_\_\_\_\_

Quantity: \_\_\_\_\_ SIS#: \_\_\_\_\_ AIA/CSI#: \_\_\_\_\_

Inches [mm]

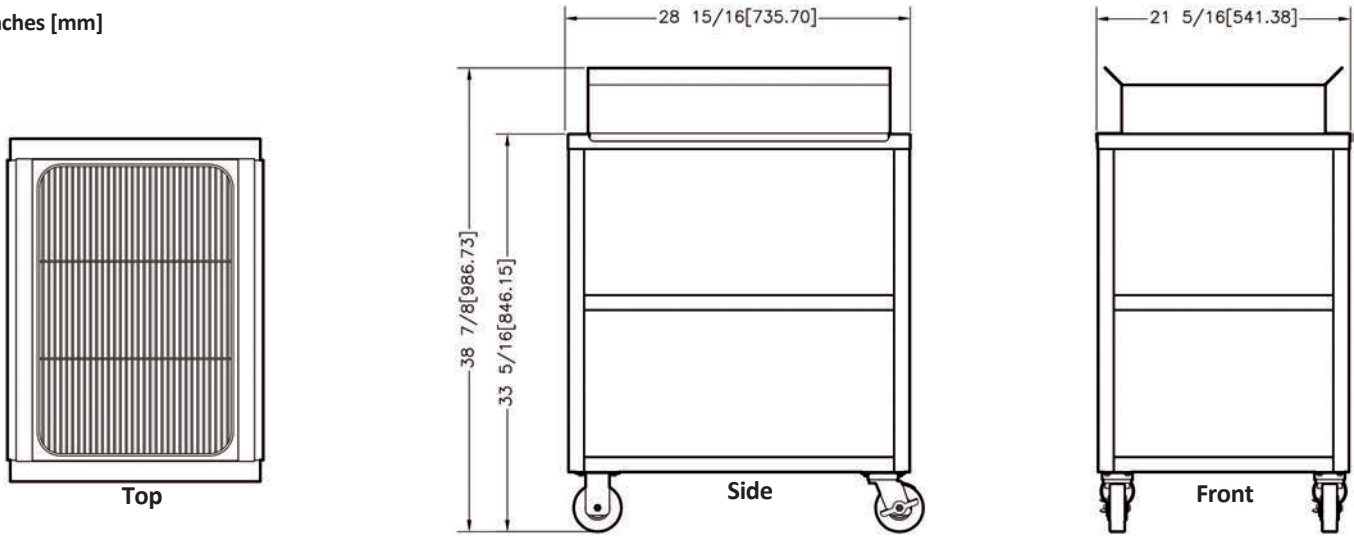

## Specifications

### Construction:

18-ga. 304 stainless steel & 16-ga. 304 welded stainless tubing

### Dimensions:

Width: 23-3/16" [590 mm]

Depth: 26-5/16" [669 mm]

Height: 36-3/8" [924 mm]

**Holding Pan:** 18-1/2" x 25-1/2" x 6" [470 mm x 648 mm x 152 mm]

**Glazing Screen:** 16-1/2" x 24-1/2" [419 mm X 622 mm]

**Sheet Pan:** 18" x 26" [457 mm X 660 mm]

**Product Designation:** LT-3

### Shipping Specifications:

Crated Weight: 79 lbs [36 kg]

Crated Cube: 24" x 28" x 37" = 15 cu ft  
[610 mm x 711 mm x 940 mm = 0.4 cu m]

## Unit Includes:

Holding Pan

(1) Glazing Screen

(1) 18" x 26" Sheet Pan

Removable Center Shelf (or Side Racks)

## How To Specify

### 1. Select Model

Qty	Model	Item Number
	LT-3 Std. w/Shelf	79592
	LT-3 w/Alternative Side Racks	79588

### 2. Extra Accessories (purchased separately)

Specify Item Number & Quantity for any of the following, as needed:

Qty	Model	Item Number
	Glazing Screen	77175
	Full-size Sheet Pan, 18" x 26"	78602
	Side Rack (2 required)	97750
	Removable Shelf	33943

### 3. Shipping

Specify the shipping method



2750 Gunter Park Drive West • Montgomery, AL 36109 USA  
334.272.1457 • Toll Free: 800.554.4537

Product specifications and/or designs are subject to changes without notice. Such revisions do not entitle the buyer to corresponding changes, improvements, additions or replacements for previously purchased equipment.

Printed in USA, Form 67380.E, Rel.Date: Nov.2011, Rev. Date: Jan.2018, Rev. E