



Responsive. Reliable.



Project Name/No: \_\_\_\_\_ Item No: \_\_\_\_\_

Quantity: \_\_\_\_\_ SIS#: \_\_\_\_\_ AIA/CSI#: \_\_\_\_\_

## Portable Landing Table

### LT-3

With a versatile **Portable LT-3 Landing Table**, you can create all of the extra workspace you may need!

- Versatile and portable worktable/cart combination.
- Convenient portable dumping station for cooked products from the fryer. Open-front Holding Pan for easy loading and unloading. Accommodates an 18" x 26" Sheet Pan. A glazing screen is provided to aid product drainage.
- When needed, remove the Pan to provide an additional worktable in the kitchen, or use to transport full food pans, soiled utensils, etc.
- An easily removable convenient Center Shelf is standard.
- Durable stainless steel construction, robust 4-1/2" Locking Swivel Casters for easy maneuverability. Lock to create a stable workstation.
- Optional side racks; each level accommodates a full-size Sheet Pan. Racks lift off easily without tools for cleaning.

### Design Features:

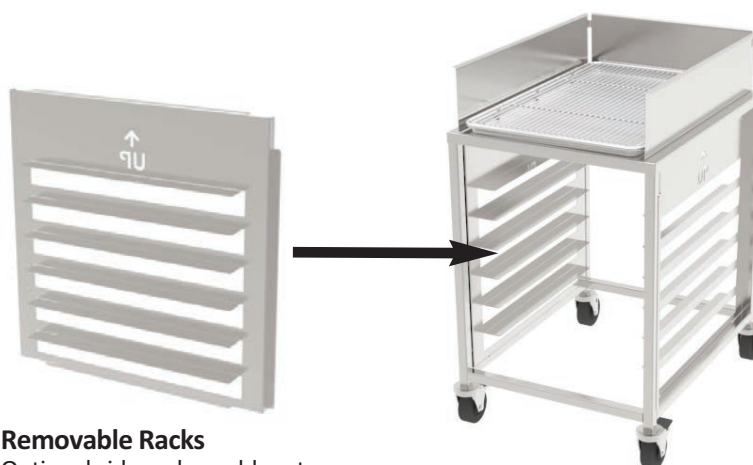

#### Removable Racks

Optional side racks - adds extra storage space, making the LT-3 a must for any foodservice operation.

**GILES Food Service Equipment** ▪ ISO 9001 Registered

PO Box 210247; 2750 Gunter Park Drive W; Montgomery, AL 36109 USA

334.272.1457 ▪ Fax 334.239.4117 ▪ Toll Free 800.554.4537 (US/Canada Only) ▪ [www.gfse.com](http://www.gfse.com) ▪ Email: [services@gfse.com](mailto:services@gfse.com)

Printed in USA, Form 67380.E, Rel.Date: Nov.2011, Rev. Date: Jan.2018, Rev. E

# Portable Landing Table

## LT-3

Project Name/No: \_\_\_\_\_ Item No: \_\_\_\_\_  
 Quantity: \_\_\_\_\_ SIS#: \_\_\_\_\_ AIA/CSI#: \_\_\_\_\_

Inches [mm]

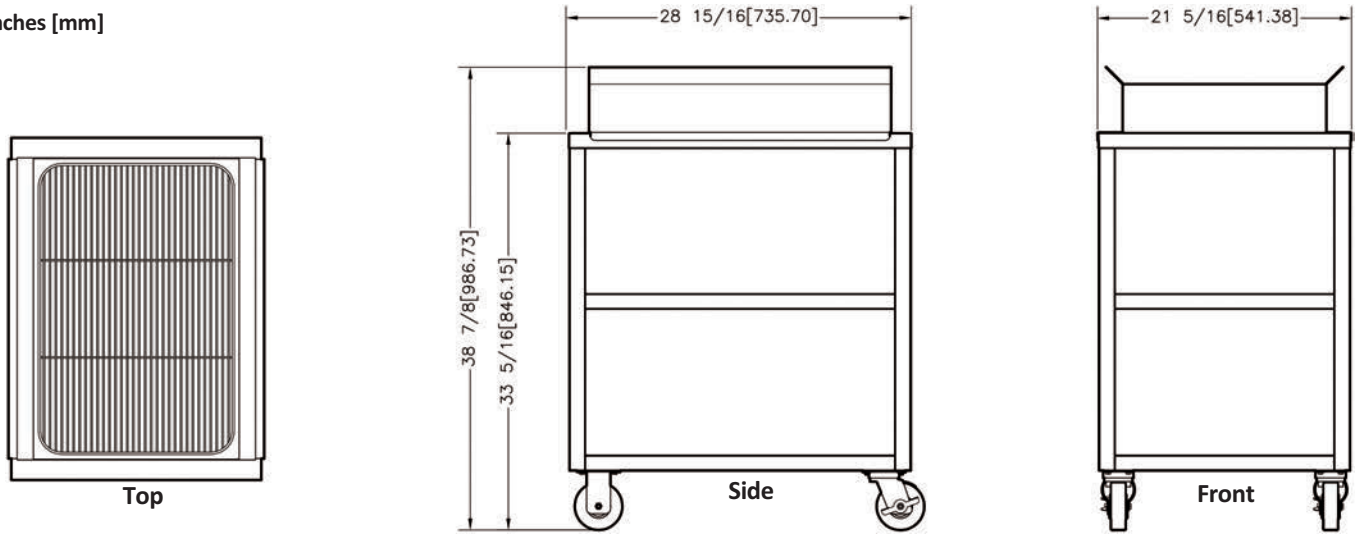

### Specifications

#### Construction:

18-Ga 430 Stainless Steel & 16-Ga 304 Stainless Tube (welded)

#### Dimensions:

Width: 23-3/16" [590 mm]  
 Depth: 26-5/16" [669 mm]  
 Height: 36-3/8" [924 mm]

**Holding Pan:** 18-1/2" x 25-1/2" x 6" [470 mm x 648 mm x 152 mm]

**Glazing Screen:** 16-1/2" x 24-1/2" [419 mm X 622 mm]

**Sheet Pan:** 18" x 26" [457 mm X 660 mm]

**Product Designation:** LT-3

#### Shipping Specifications:

Crated Weight: 79 lbs [36 kg]

Crated Cube: 24" x 28" x 37" = 15 cu ft  
 [610 mm x 711 mm x 940 mm = 0.4 cu m]

### Accessories Included

Holding Pan  
 Removable Center Shelf  
 Glazing Screen  
 18" x 26" Sheet Pan

### How To Specify

#### 1. Select Model

✓	Qty	Model	Item Number
		LT-3 Std. w/Shelf	79592
		LT-3 w/Optional Side Racks	79588

#### 2. Additional Accessories (purchased separately)

Specify Item Number and Quantity for any of the following as needed:

✓	Qty	Model	Item Number
		Glazing Screen	77175
		Full-size Sheet Pan, 18" x 26"	78602
		Side Rack (2 required)	97750
		Removable Shelf	33943

#### 3. Shipping

Specify the shipping method

### GILES Food Service Equipment

2750 Gunter Park Drive West • Montgomery, AL 36109 USA  
 Phone: 334.272.1457 • Toll Free: 800.554.4537 • Fax 334.239.4117  
 Website: www.gfse.com • Email: services@gfse.com

Product specifications and/or designs are subject to changes without notice. Such revisions do not entitle the buyer to corresponding changes, improvements, additions or replacements for previously purchased equipment.